

## References

- [1] R. Viral and D. K. Khatod, "Optimal planning of distributed generation systems in distribution system: A review," *Renewable and sustainable energy Reviews*, vol. 16, no. 7, pp. 5146–5165, 2012.
- [2] R. V. and D. K. Khatod, "An analytical approach for sizing and siting of DGs in balanced radial distribution networks for loss minimization," *International Journal of Electrical Power & Energy Systems*, vol. 67, pp. 191–201, 2015.
- [3] T. Ackermann, G. Andersson, and L. Söder, "Distributed generation: a definition," *Electric power systems research*, vol. 57, no. 3, pp. 195–204, 2001.
- [4] G. Pepermans, J. Driesen, D. Haeseldonckx, R. Belmans, and W. D'haeseleer, "Distributed generation: definition, benefits and issues," *Energy policy*, vol. 33, no. 6, pp. 787–798, 2005.
- [5] K. L. Anaya and M. G. Pollitt, "The role of distribution network operators in promoting cost-effective distributed generation: Lessons from the united states of america for europe," *Renewable and Sustainable Energy Review*, vol. 51, pp. 484–496, 2015.
- [6] V. V. Murty and A. Kumar, "Optimal placement of DG in radial distribution systems based on new voltage stability index under load growth," *International Journal of Electrical Power and Energy Systems*, vol. 69, pp. 246–256, 2015. [Online]. Available: <http://dx.doi.org/10.1016/j.ijepes.2014.12.080>
- [7] D. Singh, Y. R. Sood, and A. K. Barnwal, "Case studies on optimal location and sizing of renewable energy generators in distribution system," *Journal of Renewable and Sustainable Energy*, vol. 8, no. 6, 2016. [Online]. Available: <http://dx.doi.org/10.1063/1.4972887>
- [8] A. Singh, S. R. Ghatak, and S. Dey, "Strategic deployment of distributed generation and DSTATCOM in radial distribution system considering reliability aspect," *2018 2nd International Conference on Electronics, Materials Engineering and Nano-Technology, IEMENTech 2018*, pp. 1–6, 2018.
- [9] M. M. Aman, G. B. Jasmon, H. Mokhlis, and A. H. Bakar, "Optimal placement and sizing of a DG based on a new power stability index and line losses," *International Journal of Electrical Power and Energy Systems*, vol. 43, no. 1, pp. 1296–1304, 2012. [Online]. Available: <http://dx.doi.org/10.1016/j.ijepes.2012.05.053>

- [10] S. Kansal, V. Kumar, and B. Tyagi, "Optimal placement of different type of DG sources in distribution networks," *International Journal of Electrical Power and Energy Systems*, vol. 53, no. 1, pp. 752–760, 2013. [Online]. Available: <http://dx.doi.org/10.1016/j.ijepes.2013.05.040>
- [11] N. Acharya, P. Mahat, and N. Mithulananthan, "An analytical approach for DG allocation in primary distribution network," *International Journal of Electrical Power & Energy Systems*, vol. 28, no. 10, pp. 669–678, 2006.
- [12] D. Q. Hung, N. Mithulananthan, and R. C. Bansal, "Analytical expressions for DG allocation in primary distribution networks," *IEEE Transactions on energy conversion*, vol. 25, no. 3, pp. 814–820, 2010.
- [13] D. Q. Hung and N. Mithulananthan, "Multiple distributed generator placement in primary distribution networks for loss reduction," *IEEE Transactions on Industrial Electronics*, vol. 60, no. 4, pp. 1700–1708, 2013.
- [14] D. Q. Hung, N. Mithulananthan, and K. Y. Lee, "Determining pv penetration for distribution systems with time-varying load models," *IEEE Transactions on Power Systems*, vol. 29, no. 6, pp. 3048–3057, 2014.
- [15] D. Q. Hung, N. M., and K. Y. Lee, "Optimal placement of dispatchable and non dispatchable renewable dg units in distribution networks for minimizing energy loss," *Journal of Electrical Power Energy*, vol. 55, pp. 179–186, 2014.
- [16] N. S. Rau and Y.-h. Wan, "Optimum location of resources in distributed planning," *IEEE Transactions on Power systems*, vol. 9, no. 4, pp. 2014–2020, 1994.
- [17] P. N. Vovos and J. W. Bialek, "Direct incorporation of fault level constraints in optimal power flow as a tool for network capacity analysis," *IEEE Transactions on Power Systems*, vol. 20, no. 4, pp. 2125–2134, 2005.
- [18] A. Keane and M. O'Malley, "Optimal allocation of embedded generation on distribution networks," *IEEE Transactions on Power Systems*, vol. 20, no. 3, pp. 1640–1646, 2005.
- [19] A. K. and M. O'Malley, "Optimal utilization of distribution networks for energy harvesting," *IEEE Transactions on Power Systems*, vol. 22, no. 1, pp. 467–475, 2007.
- [20] O. Montoya, W. Gil-González, and L. Grisales-Noreña, "Relaxed convex model for optimal location and sizing of dgs in dc grids using sequential quadratic programming and random hyperplane approaches," *International journal of Electrical Power and Energy System*, vol. 115, p. 105442.
- [21] M. F. Alhajri, M. R. Alrashidi, and M. E. El-Hawary, "Improved sequential quadratic programming approach for optimal distribution generation deployments via stability and sensitivity analyses," *Electric Power Components and Systems*, vol. 38, no. 14, pp. 1595–1614, 2010.

- [22] Y. M. Atwa, E. F. El-Saadany, M. M. Salama, and R. Seethapathy, "Optimal renewable resources mix for distribution system energy loss minimization," *IEEE Transactions on Power Systems*, vol. 25, no. 1, pp. 360–370, 2010.
- [23] A. A.-T.-F. S. Porkar, P. Poure and S. Saadate, "Optimal allocation of distributed generation using a two-stage multi-objective mixed-integer-nonlinear programming," *Eur. Trans. Electr. Power*, vol. 21, no. 1, pp. 1072–1087.
- [24] W. El-Khattam and M. M. A. Salama, "Distribution system planning using distributed generation," in *CCECE 2003-Canadian Conference on Electrical and Computer Engineering. Toward a Caring and Humane Technology (Cat. No. 03CH37436)*, vol. 1. IEEE, 2003, pp. 579–582.
- [25] R. Al Abri, E. F. El-Saadany, and Y. M. Atwa, "Optimal placement and sizing method to improve the voltage stability margin in a distribution system using distributed generation," *IEEE transactions on power systems*, vol. 28, no. 1, pp. 326–334, 2012.
- [26] N. Khalesi, N. Rezaei, and M.-R. Haghifam, "Dg allocation with application of dynamic programming for loss reduction and reliability improvement," *International Journal of Electrical Power & Energy Systems*, vol. 33, no. 2, pp. 288–295, 2011.
- [27] C. L. Borges and D. M. Falcão, "Optimal distributed generation allocation for reliability, losses, and voltage improvement," *International Journal of Electrical Power and Energy Systems*, vol. 28, no. 6, pp. 413–420, 2006.
- [28] L. F. Ochoa, A. Padilha-Feltrin, and G. P. Harrison, "Time-series-based maximization of distributed wind power generation integration," *IEEE Transactions on Energy Conversion*, vol. 23, no. 3, pp. 968–974, 2008.
- [29] Y. Alinejad-Beromi, M. Sedighizadeh, and M. Sadighi, "A particle swarm optimization for siting and sizing of distributed generation in distribution network to improve voltage profile and reduce THD and losses," *Proceedings of the Universities Power Engineering Conference*, 2008.
- [30] M. Kumawat, N. Gupta, N. Jain, and R. C. Bansal, "Swarm-Intelligence-Based Optimal Planning of Distributed Generators in Distribution Network for Minimizing Energy Loss," *Electric Power Components and Systems*, vol. 45, no. 6, pp. 589–600, 2017. [Online]. Available: <https://doi.org/10.1080/15325008.2017.1290713>
- [31] R. S. Pandey and S. R. Awasthi, "A Multi-objective Hybrid Algorithm for Optimal Planning of Distributed Generation," *Arabian Journal for Science and Engineering*, vol. 45, no. 4, pp. 3035–3054, 2020. [Online]. Available: <https://doi.org/10.1007/s13369-019-04271-1>
- [32] M. Pesaran H.A., M. Nazari-Heris, B. Mohammadi-Ivatloo, and H. Seyedi, "A hybrid genetic particle swarm optimization for distributed generation allocation in power distribution networks," *Energy*, vol. 209, p. 118218, 2020. [Online]. Available: <https://doi.org/10.1016/j.energy.2020.118218>

- [33] S. Essallah and A. Khedher, "Optimization of distribution system operation by network reconfiguration and dg integration using mpso algorithm," *Renewable Energy Focus*, vol. 34, pp. 37–46, 2020.
- [34] P. Singh, N. K. Meena, S. K. Bishnoi, B. Singh, and M. Bhadu, "Hybrid elephant herding and particle swarm optimizations for optimal dg integration in distribution networks," *Electric Power Components and Systems*, vol. 48, no. 6-7, pp. 727–741, 2020.
- [35] W. Haider, S. J. U. Hassan, A. Mehdi, A. Hussain, G. O. M. Adjayeng, and C.-H. Kim, "Voltage profile enhancement and loss minimization using optimal placement and sizing of distributed generation in reconfigured network," *Machines*, vol. 9, no. 1, p. 20, 2021.
- [36] M. S. Rawat and S. Vadhera, "Heuristic optimization techniques for voltage stability enhancement of radial distribution network with simultaneous consideration of network reconfiguration and dg sizing and allocations," *Turkish Journal of Electrical Engineering and Computer Sciences*, vol. 27, no. 1, pp. 330–345, 2019.
- [37] H. WU, P. DONG, and M. LIU, "Distribution network reconfiguration for loss reduction and voltage stability with random fuzzy uncertainties of renewable energy generation and load."
- [38] A. S. Hassan, Y. Sun, and Z. Wang, "Multi-objective for optimal placement and sizing DG units in reducing loss of power and enhancing voltage profile using BPSO-SLFA," *Energy Reports*, vol. 6, pp. 1581–1589, 2020. [Online]. Available: <https://doi.org/10.1016/j.egy.2020.06.013>
- [39] S. Angalaeswari, P. Sanjeevikumar, K. Jamuna, and Z. Leonowicz, "Hybrid pipso-sqp algorithm for real power loss minimization in radial distribution systems with optimal placement of distributed generation," *Sustainability (Switzerland)*, vol. 12, no. 14, pp. 1–21, 2020.
- [40] V. V. V. S. N. Murty and A. Kumar, "Optimal dg integration and network reconfiguration in microgrid system with realistic time varying load model using hybrid optimisation," *IET Smart Grid*, vol. 2, no. 2, pp. 192–202, 2019.
- [41] S. R. Salkuti, "Optimal operation of smart distribution networks using gravitational search algorithm," *International Journal of Advanced Computer Science and Applications*, vol. 12, no. 6, 2021.
- [42] A. N. Z.-H.-C. Z. N. H. M. J. B. M. S. . S. P. M. S., Abdalla, "Optimized economic operation of energy storage integration using improved gravitational search algorithm and dual stage optimization," *Journal of Energy Storage*, vol. 50, 2022.
- [43] U. Sultana, A. B. Khairuddin, A. Mokhtar, N. Zareen, and B. Sultana, "Grey wolf optimizer based placement and sizing of multiple distributed generation in the distribution system," *Energy*, vol. 111, pp. 525–536, 2016.

- [44] D. Nataraj, R. Loganathan, M. Veerasamy, and V. D. R. Reddy, "Maximizing power loss reduction in radial distribution systems by using modified gray wolf optimization," *International Journal of Engineering and Technology Innovation*, vol. 9, no. 4, pp. 327–343, Sep. 2019.
- [45] R. Čađenović, D. Jakus, P. Sarajčev, and J. Vasilj, "Optimal distribution network reconfiguration through integration of cycle-break and genetic algorithms," *Energies*, vol. 11, no. 5, p. 1278, 2018.
- [46] M. R. Cruz, S. F. Santos, D. Z. Fitiwi, and J. P. Catalão, "Coordinated distribution network reconfiguration and distributed generation allocation via genetic algorithm."
- [47] R. S. Maciel and A. Padilha-Feltrin, "Distributed generation impact evaluation using a multi-objective tabu search," *2009 15th International Conference on Intelligent System Applications to Power Systems, ISAP '09*, 2009.
- [48] B. M. . L. Bagheri, A., "Optimal reconfiguration and dg integration in distribution networks considering switching actions costs using tabu search algorithm," *Journal of Ambient Intelligence and Humanized Computing*, vol. 12, no. 7, pp. 7837–7856, 2021.
- [49] A.-Z. M. A. M. . A.-G. S. F. Mohamed, M. A. E. H., "Energy saving maximization of balanced and unbalanced distribution power systems via network reconfiguration and optimum capacitor allocation using a hybrid metaheuristic algorithm." *Energies*, vol. 14, no. 11, p. 3205, 2021.
- [50] H. Falaghi and M. R. Haghifam, "ACO based algorithm for distributed generation sources allocation and sizing in distribution systems," *2007 IEEE Lausanne POWERTECH, Proceedings*, pp. 555–560, 2007.
- [51] C. L., Singh, "Reliability-constrained optimum placement of reclosers and distributed generators in distribution networks using an ant colony system algorithm," *IEEE Transactions on Systems, Man, and Cybernetics, Part C (Applications and Reviews)*, vol. 38, no. 6, pp. 757–764, 2008.
- [52] A. Swarnkar, N. Gupta, and K. R. Niazi, "Adapted ant colony optimization for efficient reconfiguration of balanced and unbalanced distribution systems for loss minimization," *Swarm and Evolutionary Computation*, vol. 1, no. 3, pp. 129–137, 2011.
- [53] A. I. Aly, Y. G. Hegazy, and M. A. Alsharkawy, "A simulated annealing algorithm for multi-objective distributed generation planning," *IEEE PES General Meeting, PES 2010*, pp. 1–7, 2010.
- [54] S. Nie, X.-P. Fu, P. Li, F. Gao, C.-D. Ding, H. Yu, and C.-S. Wang, "Analysis of the impact of dg on distribution network reconfiguration using openss," in *IEEE PES Innovative Smart Grid Technologies*. IEEE, 2012, pp. 1–5.
- [55] S. Koziel, A. L. Rojas, and S. Moskwa, "Power loss reduction through distribution network reconfiguration using feasibility-preserving simulated annealing."

- [56] A. A. El-Ela, R. A. El-Sehiemy, and A. S. Abbas, "Optimal Placement and Sizing of Distributed Generation and Capacitor Banks in Distribution Systems Using Water Cycle Algorithm," *IEEE Systems Journal*, vol. 12, no. 4, pp. 3629–3636, 2018.
- [57] M. A. Muhammad, H. Mokhlis, K. Naidu, A. Amin, J. F. Franco, and M. Othman, "Distribution network planning enhancement via network reconfiguration and dg integration using dataset approach and water cycle algorithm," *Journal of Modern Power Systems and Clean Energy*, vol. 8, no. 1, pp. 86–93, 2020.
- [58] S. Ibrahim, S. Alwash, and A. Aldhabab, "Optimal network reconfiguration and dg integration in power distribution systems using enhanced water cycle algorithm."
- [59] B. P. S.-. G. B. Ali, S. M., "Reconfiguration with simultaneous dg installation to improve the voltage profile in distribution network using harmony search algorithm."
- [60] S. Kayalvizhi and V. K. Vinod, "Optimal planning of active distribution networks with hybrid distributed energy resources using grid-based multi-objective harmony search algorithm," *Applied Soft Computing Journal*, vol. 67, pp. 387–398, 2018. [Online]. Available: <https://doi.org/10.1016/j.asoc.2018.03.009>
- [61] B. G. A. . G. L. P. dos Santos, M. V., "Methodology of solution for the distribution network reconfiguration problem based on improved harmony search algorithm."
- [62] H. Hamour, S. Kamel, H. Abdel-mawgoud, A. Korashy, and F. Jurado, "Distribution network reconfiguration using grasshopper optimization algorithm for power loss minimization," *International Conference on Smart Energy Systems and Technologies (SEST)*, pp. 1–5, 2018.
- [63] K. G. P. D. D. . B. R. C. S. R., Jasthi, "Grasshopper optimization algorithm based two stage fuzzy multiobjective approach for optimum sizing and placement of distributed generations, shunt capacitors and electric vehicle charging stations," *Journal of Energy Storage*, vol. 27, p. 101117, 2020.
- [64] U. Sultana, A. B. Khairuddin, B. Sultana, N. Rasheed, S. H. Qazi, and N. R. Malik, "Placement and sizing of multiple distributed generation and battery swapping stations using grasshopper optimizer algorithm," *Energy*, vol. 165, pp. 408–421, 2018.
- [65] M. C. Suresh and J. B. Edward, "A hybrid algorithm based optimal placement of DG units for loss reduction in the distribution system," *Applied Soft Computing Journal*, vol. 91, p. 106191, 2020. [Online]. Available: <https://doi.org/10.1016/j.asoc.2020.106191>
- [66] İ. Çetinbaş, B. Tamyürek, and M. Demirtaş, "Sizing optimization and design of an autonomous ac microgrid for commercial loads using harris hawks optimization algorithm," *Energy Conversion and Management*, vol. 245, p. 114562, 2021.
- [67] H. L. M. W. A. S. W. . L. Y. Rizwan, M., "Hybrid harris hawks optimizer for integration of renewable energy sources considering stochastic behavior of energy sources."

- [68] . E. E. E. ElSayed, S. K., “Hybrid harris hawks optimization with sequential quadratic programming for optimal coordination of directional overcurrent relays incorporating distributed generation.”
- [69] A. Selim, S. Kamel, and F. Jurado, “Efficient optimization technique for multiple DG allocation in distribution networks,” *Applied Soft Computing Journal*, vol. 86, p. 105938, 2020. [Online]. Available: <https://doi.org/10.1016/j.asoc.2019.105938>
- [70] A. M. Helmi, R. Carli, M. Dotoli, and H. S. Ramadan, “Efficient and sustainable reconfiguration of distribution networks via metaheuristic optimization,” *IEEE Transactions on Automation Science and Engineering*, vol. 19, no. 1, pp. 82–98, 2021.
- [71] P. Singh, S. K. Bishnoi, and N. K. Meena, “Moth Search Optimization for Optimal DERs Integration in Conjunction to OLTC Tap Operations in Distribution Systems,” *IEEE Systems Journal*, vol. 14, no. 1, pp. 880–888, 2020.
- [72] G. W. Chang and N. Cong Chinh, “Coyote optimization algorithm-based approach for strategic planning of photovoltaic distributed generation,” *IEEE Access*, vol. 8, pp. 36 180–36 190, 2020.
- [73] N. T. T. . D. B. H. Pham, T. D., “Find optimal capacity and location of distributed generation units in radial distribution networks by using enhanced coyote optimization algorithm.”
- [74] H. Alghamdi, “Optimum placement of distribution generation units in power system with fault current limiters using improved coyote optimization algorithm,” *Entropy*, vol. 23, no. 6, p. 655, 2021.
- [75] W. Tan, M. Hassan, M. Majid, and H. Rahman, “Allocation and sizing of dg using cuckoo search algorithm,” in *2012 IEEE international conference on power and energy (PECon)*. IEEE, 2012, pp. 133–138.
- [76] T. Yuvaraj and K. Ravi, “Multi-objective simultaneous dg and dstatcom allocation in radial distribution networks using cuckoo searching algorithm,” *Alexandria engineering journal*, vol. 57, no. 4, pp. 2729–2742, 2018.
- [77] E. Karunarathne, J. Pasupuleti, J. Ekanayake, and D. Almeida, “Optimal placement and sizing of dgs in distribution networks using mlpsa algorithm,” *Energies*, vol. 13, no. 23, 2020. [Online]. Available: <https://www.mdpi.com/1996-1073/13/23/6185>
- [78] Q. Zhao, S. Wang, K. Wang, and B. Huang, “Multi-objective optimal allocation of distributed generations under uncertainty based on D-S evidence theory and affine arithmetic,” *International Journal of Electrical Power and Energy Systems*, vol. 112, no. 92, pp. 70–82, 2019. [Online]. Available: <https://doi.org/10.1016/j.ijepes.2019.04.044>
- [79] A. Bayat and A. Bagheri, “Optimal active and reactive power allocation in distribution networks using a novel heuristic approach,” *Applied Energy*, vol. 233-234, no. April 2018, pp. 71–85, 2019. [Online]. Available: <https://doi.org/10.1016/j.apenergy.2018.10.030>

- [80] J. M. Home-Ortiz, M. Pourakbari-Kasmaei, M. Lehtonen, and J. R. S. Mantovani, "Optimal location-allocation of storage devices and renewable-based DG in distribution systems," *Electric Power Systems Research*, vol. 172, pp. 11–21, 2019.
- [81] F. C. R. Coelho, I. C. da Silva Junior, B. H. Dias, W. Peres, V. H. Ferreira, and A. L. M. Marcato, "Optimal distributed generation allocation in unbalanced radial distribution networks via empirical discrete metaheuristic and steepest descent method," *Electrical Engineering*, vol. 103, no. 1, pp. 633–646, 2021. [Online]. Available: <https://doi.org/10.1007/s00202-020-01106-3>
- [82] K. H. Truong, P. Nallagownden, I. Elamvazuthi, and D. N. Vo, "An improved meta-heuristic method to maximize the penetration of distributed generation in radial distribution networks," *Neural Computing and Applications*, vol. 32, no. 14, pp. 10 159–10 181, 2020. [Online]. Available: <https://doi.org/10.1007/s00521-019-04548-4>
- [83] A. Bayat, A. Bagheri, and R. Noroozian, "Optimal siting and sizing of distributed generation accompanied by reconfiguration of distribution networks for maximum loss reduction by using a new UVDA-based heuristic method," *International Journal of Electrical Power and Energy Systems*, vol. 77, pp. 360–371, 2016. [Online]. Available: <http://dx.doi.org/10.1016/j.ijepes.2015.11.039>
- [84] S. L. Edathil and S. P. Singh, "ACO and CS-based hybrid optimisation method for optimum sizing of the SHES," *IET Renewable Power Generation*, 2019.
- [85] A. K. Barnwal, L. K. Yadav, and M. K. Verma, "A multi-objective approach for voltage stability enhancement and loss reduction under pqv and p buses through reconfiguration and distributed generation allocation," *IEEE Access*, 2022.
- [86] R. C. C. S. A. S. A. Onlam, D. Yodphet and P. Khunkitti, "Power loss minimization and voltage stability improvement in electrical distribution system via network reconfiguration and distributed generation placement using novel adaptive shuffled frogs leaping algorithm," *Energies*, vol. 12, no. 3, p. 553, 2019.
- [87] U. Raut and S. Mishra, "An improved elitist-jaya algorithm for simultaneous network reconfiguration and dg allocation in power distribution systems," *Renewable Energy Focus*, vol. 30, pp. 92–106, 2019.
- [88] B. D. J. Shukla and V. Pant, "Stability constrained optimal distribution system reconfiguration considering uncertainties in correlated loads and distributed generations," *International Journal of Electrical Power Energy System*, vol. 99, no. October 2017.
- [89] K. S. Sambaiah and T. Jayabarathi, "Optimal reconfiguration and renewable distributed generation allocation in electric distribution systems," *International Journal of Ambient Energy*, vol. 42, no. 9, pp. 1018–1031, 2021.
- [90] S. A.-N. A. Jafar-Nowdeh, M. Babanezhad, "Meta-heuristic matrix moth-flame algorithm for optimal reconfiguration of distribution networks and placement of solar and wind renewable sources considering reliability," *Environment Technology and Innovation*, vol. 20, no. 1, p. 101118, 2020.

- [91] K. S. Sambaiah and T. Jayabarathi, “Optimal reconfiguration and renewable distributed generation allocation in electric distribution systems,” *International Journal of Ambient Energy*, pp. 1–8, 2018.
- [92] U. Raut and S. Mishra, “An improved sine–cosine algorithm for simultaneous network reconfiguration and dg allocation in power distribution systems,” *Applied Soft Computing*, vol. 92, p. 106293, 2020.
- [93] S. Ganesh and R. Kanimozhi, “Meta-heuristic technique for network reconfiguration in distribution system with photovoltaic and d-statcom,” *IET Generation, Transmission & Distribution*, vol. 12, no. 20, pp. 4524–4535, 2018.
- [94] I. A. Quadri, S. Bhowmick, and D. Joshi, “A comprehensive technique for optimal allocation of distributed energy resources in radial distribution systems,” *Applied Energy*, vol. 211, no. July 2017, pp. 1245–1260, 2018. [Online]. Available: <https://doi.org/10.1016/j.apenergy.2017.11.108>
- [95] T. T. Tran, K. H. Truong, and D. N. Vo, “Stochastic fractal search algorithm for reconfiguration of distribution networks with distributed generations,” *Ain Shams Engineering Journal*, vol. 11, no. 2, pp. 389–407, 2020.
- [96] B. Singh and J. Sharma, “A review on distributed generation planning,” *Renewable and Sustainable Energy Reviews*, vol. 76, no. December 2015, pp. 529–544, 2017. [Online]. Available: <http://dx.doi.org/10.1016/j.rser.2017.03.034>
- [97] M. H. Moradi and M. Abedini, “A combination of genetic algorithm and particle swarm optimization for optimal DG location and sizing in distribution systems,” *International Journal of Electrical Power and Energy Systems*, vol. 34, no. 1, pp. 66–74, 2012. [Online]. Available: <http://dx.doi.org/10.1016/j.ijepes.2011.08.023>
- [98] M. Chakravorty and D. Das, “Voltage stability analysis of radial distribution networks,” *International Journal of Electrical Power & Energy Systems*, vol. 23, no. 2, pp. 129–135, 2001.
- [99] V. Janamala and T. K. S. Pandraju, “Static voltage stability of reconfigurable radial distribution system considering voltage dependent load models,” *Mathematical Modelling of Engineering Problems*, vol. 7, no. 3, pp. 450–458, 2020.
- [100] J. C. Bansal, *Particle Swarm Optimization*. Springer International Publishing, 2019.
- [101] S. Mirjalili, S. M. Mirjalili, and A. Lewis, “Grey Wolf Optimizer,” *Advances in Engineering Software*, vol. 69, pp. 46–61, 2014. [Online]. Available: <http://dx.doi.org/10.1016/j.advengsoft.2013.12.007>
- [102] F. A. Şenel, F. Gökçe, A. S. Yüksel, and T. Yiğit, “A novel hybrid PSO–GWO algorithm for optimization problems,” *Engineering with Computers*, vol. 35, no. 4, pp. 1359–1373, 2019. [Online]. Available: <http://dx.doi.org/10.1007/s00366-018-0668-5>

- [103] S. Sultana and P. K. Roy, "Multi-objective quasi-oppositional teaching learning based optimization for optimal location of distributed generator in radial distribution systems," *International Journal of Electrical Power and Energy Systems*, vol. 63, pp. 534–545, 2014. [Online]. Available: <http://dx.doi.org/10.1016/j.ijepes.2014.06.031>
- [104] E. Rashedi, H. Nezamabadi-pour, and S. Saryazdi, "GSA: A Gravitational Search Algorithm," *Information Sciences*, vol. 179, no. 13, pp. 2232–2248, 2009. [Online]. Available: <http://dx.doi.org/10.1016/j.ins.2009.03.004>
- [105] S. Salcedo-Sanz, J. Del Ser, I. Landa-Torres, S. Gil-López, and J. Portilla-Figueras, "The coral reefs optimization algorithm: a novel metaheuristic for efficiently solving optimization problems," *The Scientific World Journal*, vol. 2014, 2014.
- [106] P. V. Babu and S. Singh, "Optimal placement of dg in distribution network for power loss minimization using nlp & pls technique," *Energy Procedia*, vol. 90, pp. 441–454, 2016.
- [107] R. Sanjay, T. Jayabarathi, T. Raghunathan, V. Ramesh, and N. Mithulananthan, "Optimal allocation of distributed generation using hybrid grey Wolf optimizer," *IEEE Access*, vol. 5, no. c, pp. 14 807–14 818, 2017.
- [108] S. Kansal, V. Kumar, and B. Tyagi, "Hybrid approach for optimal placement of multiple dgs of multiple types in distribution networks," *International Journal of Electrical Power & Energy Systems*, vol. 75, pp. 226–235, 2016.
- [109] K. Mahmoud, N. Yorino, and A. Ahmed, "Optimal distributed generation allocation in distribution systems for loss minimization," *IEEE Transactions on Power Systems*, vol. 31, no. 2, pp. 960–969, 2015.
- [110] R. Berg, E. Hawkins, and W. Pleines, "Mechanized calculation of unbalanced load flow on radial distribution circuits," *IEEE Transactions on power apparatus and systems*, no. 4, pp. 415–421, 1967.
- [111] E. Vaahedi, M. Fl-Kady, J. Libaque-Esaine, and V. Carvalho, "Load models for large-scale stability studies from end-user consumption," *IEEE transactions on power systems*, vol. 2, no. 4, pp. 864–870, 1987.
- [112] M. Baran and F. Wu, "Network reconfiguration in distribution systems for loss reduction and load balancing," *IEEE Transactions on Power Delivery*, vol. 4, no. 2, pp. 1401–1407, 1989.
- [113] J. Savier and D. Das, "Impact of network reconfiguration on loss allocation of radial distribution systems," *IEEE Transactions on Power Delivery*, vol. 22, no. 4, pp. 2473–2480, 2007.
- [114] D. Zhang, Z. Fu, and L. Zhang, "An improved ts algorithm for loss-minimum reconfiguration in large-scale distribution systems," *Electric power systems research*, vol. 77, no. 5-6, pp. 685–694, 2007.

# Appendix A

## DATA FOR 33-BUS IEEE NETWORK

IEEE 33-bus Radial Distribution System (RDS) [112] has been considered as first test system for the work carried out in this thesis. Line data and load data details of the system are presented in the Table A.1. Single line diagram is shown in Fig. A.1.

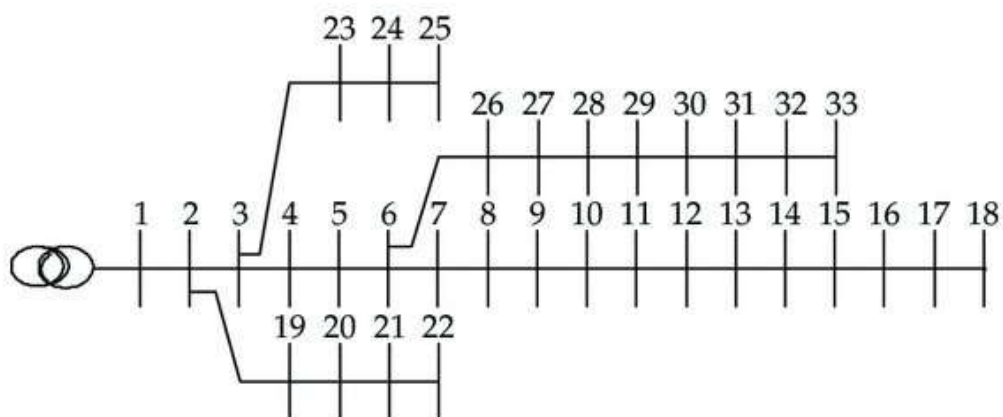

Fig. A.1 IEEE 33-bus radial distribution system

Table A.1 Line data and load data for IEEE 33-bus RDS

<b>Sending node</b>	<b>Receiving node</b>	<b>Active Power Receiving node (kW)</b>	<b>Reactive Power Receiving node (kVAr)</b>	<b>Resistance (<math>\Omega</math>)</b>	<b>Reactance (<math>\Omega</math>)</b>
1	2	100	60	0.0922	0.0470
2	3	90	40	0.4930	0.2511
3	4	120	80	0.3660	0.1864
4	5	60	30	0.3811	0.1941
5	6	60	20	0.8190	0.7070
6	7	200	100	0.1872	0.6188
7	8	200	100	1.7114	1.2351
8	9	60	20	1.0300	0.7400
9	10	60	20	1.0440	0.7400
10	11	45	30	0.1966	0.0650
11	12	60	35	0.3744	0.1238
12	13	60	35	1.4680	1.1550
13	14	120	80	0.5416	0.7129
14	15	60	10	0.5910	0.5260
15	16	60	20	0.7463	0.5450
16	17	60	20	1.2890	1.7210
17	18	90	40	0.7320	0.5740
2	19	90	40	0.1640	0.1565
19	20	90	40	1.5042	1.3554
20	21	90	40	0.4095	0.4784
21	22	90	40	0.7089	0.9373
3	23	90	50	0.4512	0.3083
23	24	420	200	0.8980	0.7091
24	25	420	200	0.8960	0.7011
5	26	60	25	0.2030	0.1034
26	27	60	25	0.2842	0.1447
27	28	60	20	1.0590	0.9337
28	29	120	70	0.8042	0.7006
29	30	200	600	0.5075	0.2585
30	31	150	70	0.9744	0.9630
31	32	210	100	0.3105	0.3619
32	33	60	40	0.3410	0.5302

# Appendix B

## DATA FOR 69-BUS IEEE NETWORK

IEEE 69-bus Radial Distribution System (RDS) [113] has been considered as second test system for the work carried out in this thesis. Line data and load data details of the system are presented in the Table B.1. Single line diagram is shown in Fig. B.1.

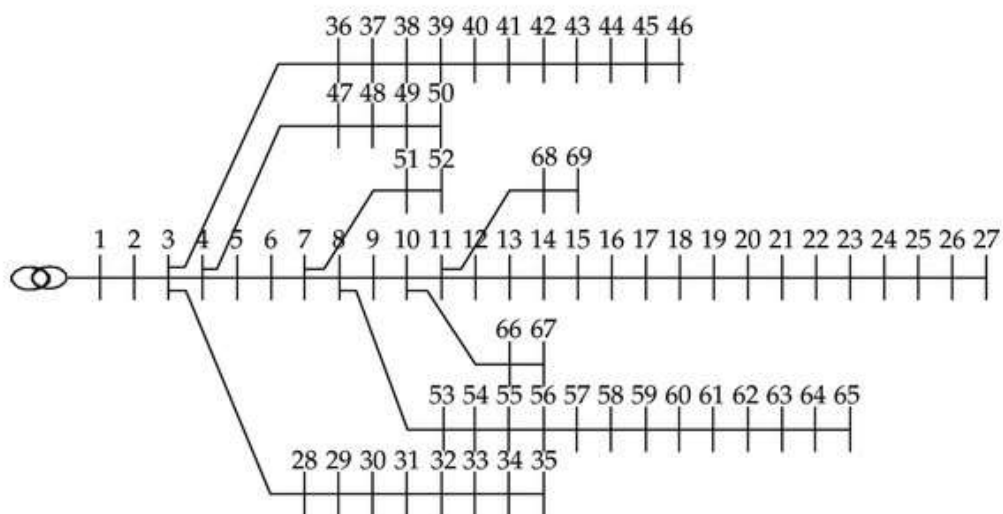

Fig. B.1 IEEE 69-bus radial distribution system

Table B.1 Line data and load data for IEEE 69-bus RDS

<b>Sending node</b>	<b>Receiving node</b>	<b>Active Power Receiving node (kW)</b>	<b>Reactive Power Receiving node (kVAr)</b>	<b>Resistance (<math>\Omega</math>)</b>	<b>Reactance (<math>\Omega</math>)</b>
1	2	0	0	0.0005	0.0012
2	3	0	0	0.0005	0.0012
3	4	0	0	0.0015	0.0036
4	5	2.6	2.2	0.0251	0.0294
5	6	40.4	30	0.3660	0.1864
6	7	75	54	0.3811	0.1941
7	8	30	22	0.0922	0.0470
8	9	28	19	0.0493	0.0251
9	10	145	104	0.8190	0.2707
10	11	145	104	0.1872	0.0619
11	12	8	5.5	2.6622	1.2351
12	13	8	5.5	1.0300	0.3400
13	14	0	0	1.0440	0.3450
14	15	45.4	30	1.0580	0.3496
15	16	60	35	0.1966	0.0650
16	17	60	35	0.3744	0.1238
17	18	0	0	0.0047	0.0016
18	19	0	0	0.3276	0.1083
19	20	1	0.6	0.2106	0.0696
20	21	114	81	0.3416	0.1129
21	22	5.3	3.5	0.0140	0.0046
22	23	0	0	0.1591	0.0526
23	24	28	20	0.3463	0.1145
24	25	0	0	0.7488	0.2475
25	26	14	10	0.3089	0.1021
26	27	14	10	0.1732	0.0572
3	28	26	18.6	0.0044	0.0108
28	29	26	18.6	0.0640	0.1565
29	30	0	0	0.3978	0.1315
30	31	0	0	0.0702	0.0232
31	32	0	0	0.3510	0.1160
32	33	14	10	0.8390	0.2816
33	34	19.5	14	1.7080	0.5646
34	35	6	4	1.4740	0.4673
3	36	26	18.55	0.0044	0.0108

<b>Sending node</b>	<b>Receiving node</b>	<b>Active Power Receiving node (kW)</b>	<b>Reactive Power Receiving node (kVAr)</b>	<b>Resistance (<math>\Omega</math>)</b>	<b>Reactance (<math>\Omega</math>)</b>
36	37	26	18.55	0.0640	0.1565
37	38	0	0	0.1053	0.1230
38	39	24	17	0.0304	0.0355
39	40	24	17	0.0018	0.0021
40	41	1.2	1	0.7283	0.8509
41	42	0	0	0.3100	0.3623
42	43	6	4.3	0.0410	0.0478
43	44	0	0	0.0092	0.0116
44	45	39.22	26.3	0.1089	0.1373
45	46	39.22	26.3	0.0009	0.0012
4	47	0	0	0.0034	0.0084
47	48	79	56.4	0.0851	0.2083
48	49	384.7	274.5	0.2898	0.7091
49	50	384.7	274.5	0.0822	0.2011
8	51	40.5	28.3	0.0928	0.0473
51	52	3.6	2.7	0.3319	0.1114
9	53	4.35	3.5	0.1740	0.0886
53	54	26.4	19	0.2030	0.1034
54	55	24	17.2	0.2842	0.1447
55	56	0	0	0.2813	0.1433
56	57	0	0	1.5900	0.5337
57	58	0	0	0.7837	0.2630
58	59	100	72	0.3042	0.1006
59	60	0	0	0.3861	0.1172
60	61	1244	888	0.5075	0.2585
61	62	32	23	0.0974	0.0496
62	63	0	0	0.1450	0.0738
63	64	227	162	0.7105	0.3619
64	65	59	42	1.0410	0.5302
11	66	18	13	0.2012	0.0611
66	67	18	13	0.0047	0.0014
12	68	28	20	0.7394	0.2444
68	69	28	20	0.0047	0.0016



# Appendix C

## DATA FOR 118-BUS IEEE NETWORK

IEEE 118-bus Radial Distribution System (RDS) [114] has been considered as third test system for the work carried out in this thesis. Line data and load data details of the system are presented in the Table C.1. Single line diagram is shown in Fig. C.1.

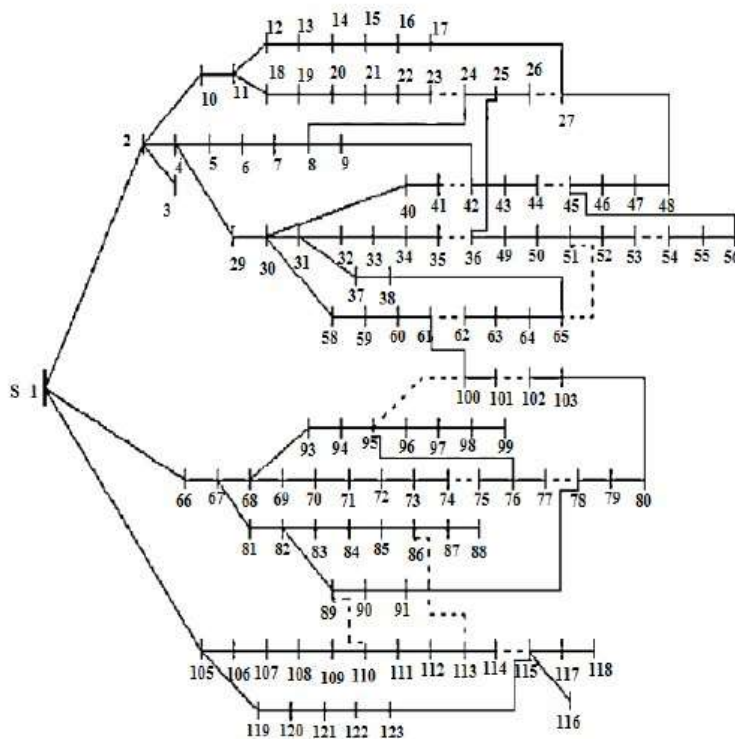

Fig. C.1 IEEE 118-bus radial distribution system

Table C.1 Line data and load data for IEEE 118-bus RDS

<b>Sending node</b>	<b>Receiving node</b>	<b>Active Power Receiving Node (kW)</b>	<b>Reactive Power Receiving Node (kVAR)</b>	<b>Resistance (<math>\Omega</math>)</b>	<b>Reactance (<math>\Omega</math>)</b>
1	2	133.8400	101.1400	0.0360	0.0130
2	3	16.2140	11.2920	0.0330	0.0119
2	4	34.3150	21.8450	0.0450	0.0162
4	5	73.0160	63.6020	0.0150	0.0540
5	6	144.2000	68.6040	0.0150	0.0540
6	7	104.4700	61.7250	0.0150	0.0125
7	8	28.5470	11.5030	0.0180	0.0140
8	9	87.5600	51.0730	0.0210	0.0630
2	10	198.2000	106.7700	0.1660	0.1344
10	11	146.8000	75.9950	0.1120	0.0789
11	12	26.0400	18.6870	0.1870	0.3130
12	13	52.1000	23.2200	0.1420	0.1512
13	14	141.9000	117.5000	0.1800	0.1180
14	15	21.8700	28.7900	0.1500	0.0450
15	16	33.3700	26.4500	0.1600	0.1800
16	17	32.4000	25.2300	0.1570	0.1700
11	18	20.2340	11.9060	0.2180	0.2850
18	19	156.9400	78.5230	0.1180	0.1850
19	20	546.2900	351.4000	0.1600	0.1960
20	21	180.3100	164.2000	0.1200	0.1890
21	22	93.16700	54.5940	0.1200	0.0789
22	23	85.1800	39.6500	1.4100	0.7230
23	24	168.1000	95.1780	0.2930	0.1348
24	25	125.1100	150.2200	0.1330	0.1040
25	26	16.0300	24.6200	0.1780	0.1340
26	27	26.0300	24.6200	0.1780	0.1340
4	28	594.5600	522.6200	0.0150	0.0296
28	29	120.6200	59.1170	0.0120	0.0276
29	30	102.3800	99.5540	0.1200	0.2766
30	31	513.4000	318.5000	0.2100	0.2430
31	32	475.2500	456.1400	0.1200	0.0540
32	33	151.4300	136.7900	0.1780	0.2340
33	34	205.3800	83.3020	0.1780	0.2340
34	35	131.6000	93.0820	0.1540	0.1620
30	36	448.4000	369.7900	0.1870	0.2610
36	37	440.5200	321.6400	0.1330	0.0990
29	38	112.5400	55.1340	0.3300	0.1940
38	39	53.9630	38.9980	0.3100	0.1940
39	40	393.0500	342.6000	0.1300	0.1940

<b>Sending node</b>	<b>Receiving node</b>	<b>Active Power Receiving node (kW)</b>	<b>Reactive Power Receiving node (kVAR)</b>	<b>Resistance (<math>\Omega</math>)</b>	<b>Reactance (<math>\Omega</math>)</b>
40	41	326.7400	278.5600	0.2800	0.1500
41	42	536.2600	240.2400	1.1800	0.8500
42	43	76.2470	66.5620	0.4200	0.2436
43	44	53.5200	39.7600	0.2700	0.0972
44	45	40.3280	31.9640	0.3390	0.1221
45	46	39.6530	20.7580	0.2700	0.1779
35	47	66.1950	42.3610	0.2100	0.1383
47	48	73.9040	51.6530	0.1200	0.0789
48	49	114.7700	57.9650	0.1500	0.0987
49	50	918.3700	1,205.1000	0.1500	0.0987
50	51	210.3000	146.6600	0.2400	0.1581
51	52	66.6800	56.6080	0.1200	0.0789
52	53	42.2070	40.1840	0.4050	0.1458
53	54	433.7400	283.4100	0.4050	0.1458
29	55	62.1000	26.8600	0.3910	0.1410
55	56	92.4600	88.3800	0.4060	0.1461
56	57	85.1880	55.4360	0.4060	0.1461
57	58	345.3000	332.4000	0.7060	0.5461
58	59	22.5000	16.8300	0.3380	0.1218
59	60	80.5510	49.1560	0.3380	0.1218
60	61	95.8600	90.7580	0.2070	0.0747
61	62	62.9200	47.7000	0.2470	0.8922
1	63	478.8000	463.7400	0.0280	0.0418
63	64	120.9400	52.0060	0.1170	0.2016
64	65	139.1100	100.3400	0.2550	0.0918
65	66	391.7800	193.5000	0.2100	0.0759
66	67	27.7410	26.7130	0.3830	0.1380
67	68	52.8140	25.2570	0.5040	0.3303
68	69	66.8900	38.7130	0.4000	0.1461
69	70	467.5000	395.1400	0.9620	0.7610
70	71	594.8500	239.7400	0.1650	0.0600
71	72	132.5000	84.3630	0.3030	0.1092
72	73	52.6990	22.4820	0.3030	0.1092
73	74	869.7900	614.7750	0.2060	0.1440
74	75	31.3490	29.8170	0.2330	0.0840
75	76	192.3900	122.4300	0.5910	0.1773
76	77	65.7500	45.3700	0.1260	0.0453
64	78	238.1500	223.2200	0.5590	0.3687
78	79	294.5500	162.4700	0.1860	0.1227
79	80	485.5700	437.9200	0.1860	0.1227
80	81	243.5300	183.0300	0.2600	0.1390

<b>Sending node</b>	<b>Receiving node</b>	<b>Active Power Receiving node (kW)</b>	<b>Reactive Power Receiving node (kVAr)</b>	<b>Resistance (<math>\Omega</math>)</b>	<b>Reactance (<math>\Omega</math>)</b>
81	82	243.5300	183.0300	0.1540	0.1480
82	83	134.2500	119.2900	0.2300	0.1280
83	84	22.7100	27.9600	0.2520	0.1060
84	85	49.5130	26.5150	0.1800	0.1480
79	86	383.7800	257.1600	0.1600	0.1820
86	87	49.6400	20.6000	0.2000	0.2300
87	88	22.4730	11.8060	0.1600	0.3930
65	89	62.9300	42.9600	0.6690	0.2412
89	90	30.6700	34.9300	0.2660	0.1227
90	91	62.5300	66.7900	0.2660	0.1227
91	92	114.5700	81.7480	0.2660	0.1227
92	93	81.2920	66.5260	0.2660	0.1227
93	94	31.7330	15.9600	0.2330	0.1150
94	95	33.3200	60.4800	0.4960	0.1380
91	96	531.2800	224.8500	0.1960	0.1800
96	97	507.0300	367.4200	0.1960	0.1800
97	98	26.3900	11.7000	0.1866	0.1220
98	99	45.9900	30.3920	0.0746	0.3180
1	100	100.6600	47.5720	0.0625	0.0265
100	101	456.4800	350.3000	0.1501	0.2340
101	102	522.5600	449.2900	0.1347	0.0888
102	103	408.4300	168.4600	0.2307	0.1203
103	104	141.4800	134.2500	0.4470	0.1608
104	105	104.4300	66.0240	0.1632	0.0588
105	106	96.7930	83.6470	0.3300	0.0990
106	107	493.9200	419.3400	0.1560	0.0561
107	108	225.3800	135.8800	0.3819	0.1374
108	109	509.2100	387.2100	0.1626	0.0585
109	110	188.5000	173.4600	0.3819	0.1374
110	111	918.0300	898.5500	0.2445	0.0879
110	112	305.0800	215.3700	0.2088	0.0753
112	113	54.3800	40.9700	0.2301	0.0828
100	114	211.1400	192.9000	0.6102	0.2196
114	115	67.0090	53.3360	0.1866	0.1270
115	116	162.0700	90.3210	0.3732	0.2460
116	117	48.7850	29.1560	0.4050	0.3670
117	118	33.9000	18.9800	0.4890	0.4380

# List of Publications

## Journal

1. **Lokesh Kumar Yadav**, Mitresh Kumar Verma and Puneet Joshi, "Novel Real Valued Improved Coral-Reef Optimization Algorithm for Optimal Integration of Classified Distributed Generators", *IEEE Access*, 10, pp.80623–80638, 2022.

2. **Lokesh Kumar Yadav**, Mitresh Kumar Verma, "Optimal Integration of Classified Dispersed Generation Units for Loss Minimization and Voltage Profile Enhancement in Radial Distribution Networks.", *Journal of Electrical Systems*, 03, pp.354–368, 2022.

## Book Chapter

3. **Lokesh Kumar Yadav**, Mitresh Kumar Verma and Puneet Joshi, "Optimal Sizing and Siting of Multiple Dispersed Generation System Using Metaheuristic Algorithm.", *International Conference on Advances in Computing and Data Sciences-2021*, published in *Communications in Computer and Information Science*, Springer, 23, pp. 268-278, 2021.

## Unpublished

4. **Lokesh Kumar Yadav**, Mitresh Kumar Verma, and Puneet Joshi, 2023, "Voltage Stability Indices for Renewable Energy: A Qualitative Analysis". *Computers and Electri-*

*cal Engineering*, Elsevier. (*submitted*).

5. **Lokesh Kumar Yadav**, Akhilesh Kumar Barnwal and Mitresh kumar Verma , 2022, "Optimal Reconfiguration of Radial Distribution Networks using PSO-CRO Algorithm for Loss Minimization and Voltage Stability Enhancement under Voltage Dependent Loads". *International conference on Energy Technologies for Future Grids (IEEE ETFG 2023)*, December 3-6, 2023, Wollongong, Australia (submitted).

\*\*\*\*\*