

# References

- [1] P. Kundur, “Power system stability and control,” *New York, McGraw-Hill*, 1994.
- [2] A. Sheykhsarraf, M. Abedini, and M. Davarpanah, “A novel method for optimal placement and tuning of the power system stabilizer in the multi-machine system,” *Electric Power Systems Research*, vol. 221, page no. 109451, 2023.
- [3] I. Zenelis, X. Wang, and I. Kamwa, “Online PMU-based wide-area damping control for multiple inter-area modes,” *IEEE Transactions on Smart Grid*, vol. 11, no. 6, pp. 5451–5461, 2020.
- [4] M. J. Morshed and A. Fekih, “A probabilistic robust coordinated approach to stabilize power oscillations in DFIG-based power systems,” *IEEE Transactions on Industrial Informatics*, vol. 15, no. 10, pp. 5599–5612, 2019.
- [5] A. Prakash, P. Singh, K. Kumar, and S. Parida, “Design of a reduced-order WADC for wind turbine system-integrated power system,” *IEEE Transactions on Industry Applications*, vol. 58, no. 3, pp. 3250–3260, 2022.
- [6] L. Zhou, X. Yu, B. Li, C. Zheng, J. Liu, Q. Liu, and K. Guo, “Damping inter-area oscillations with large-scale PV plant by modified multiple-model adaptive control strategy,” *IEEE Transactions on Sustainable Energy*, vol. 8, no. 4, pp. 1629–1636, 2017.
- [7] A. Prakash, K. Kumar, and S. Parida, “Energy capacitor system based wide-area damping controller for multiple inter-area modes,” *IEEE Transactions on Industry Applications*, vol. 58, no. 2, pp. 1543–1553, 2022.
- [8] W. Du, X. Chen, and H. F. Wang, “Impact of dynamic interactions introduced

- by the DFIGs on power system electromechanical oscillation modes,” *IEEE Transactions on Power Systems*, vol. 32, no. 6, pp. 4954–4967, 2017.
- [9] J. Bhukya, “Enhancing the wind farm-based power system stability with coordinated tuned supplementary controller,” *International Journal of Circuit Theory and Applications*, vol. 51, no. 12, pp. 5878–5907, 2023.
- [10] D. Gautam, V. Vittal, and T. Harbour, “Impact of increased penetration of DFIG-based wind turbine generators on transient and small signal stability of power systems,” *IEEE Transactions on Power Systems*, vol. 24, no. 3, pp. 1426–1434, 2009.
- [11] T. Surinkaew and I. Ngamroo, “Hierarchical co-ordinated wide area and local controls of DFIG wind turbine and PSS for robust power oscillation damping,” *IEEE Transactions on Sustainable Energy*, vol. 7, no. 3, pp. 943–955, 2016.
- [12] A. Waheed Kumar, M. U. din Mufti, and M. Yaqoob Zargar, “Utilization of superconducting magnetic energy storage and doubly fed induction generator for enhancing stability of interconnected power system,” *International Journal of Circuit Theory and Applications*, vol. 51, no. 11, pp. 5251–5268, 2023.
- [13] S. Li, H. Zhang, Y. Yan, and J. Ren, “Parameter optimization to power oscillation damper (POD) considering its impact on the DFIG,” *IEEE Transactions on Power Systems*, vol. 37, no. 2, pp. 1508–1518, 2021.
- [14] C. Zhang, D. Ke, Y. Sun, C. Chung, J. Xu, and F. Shen, “Coordinated supplementary damping control of DFIG and PSS to suppress inter-area oscillations with optimally controlled plant dynamics,” *IEEE Transactions on Sustainable Energy*, vol. 9, no. 2, pp. 780–791, 2017.
- [15] P. He, Q. Fang, H. Jin, Y. Ji, Z. Gong, and J. Dong, “Coordinated design of PSS and STATCOM-POD based on the GA-PSO algorithm to improve the stability of wind-PV-thermal-bundled power system,” *International Journal of Electrical Power & Energy Systems*, vol. 141, page no. 108208, 2022.
- [16] K. Tahir, T. Allaoui, M. Denai, S. Mekhilef, C. Belfedal, and M. Doumi, “Second-order sliding mode control of wind turbines to enhance the fault-ride through

- capability under unbalanced grid faults,” *International Journal of Circuit Theory and Applications*, vol. 49, no. 7, pp. 1959–1986, 2021.
- [17] F. Calero, C. A. Cañizares, and K. Bhattacharya, “Dynamic modeling of battery energy storage and applications in transmission systems,” *IEEE Transactions on Smart Grid*, vol. 12, no. 1, pp. 589–598, 2020.
- [18] U. Datta, A. Kalam, and J. Shi, “Battery energy storage system to stabilize transient voltage and frequency and enhance power export capability,” *IEEE Transactions on Power Systems*, vol. 34, no. 3, pp. 1845–1857, 2018.
- [19] B. F. Hobbs and F. A. Rijkers, “Strategic generation with conjectured transmission price responses in a mixed transmission pricing system-part I: formulation,” *IEEE Transactions on Power Systems*, vol. 19, no. 2, pp. 707–717, 2004.
- [20] H. Silva-Saravia, Horacio and Pulgar-Painemal and J. M. Mauricio, “Flywheel energy storage model, control and location for improving stability: The Chilean case,” *IEEE Transactions on Power Systems*, vol. 32, no. 4, pp. 3111–3119, 2016.
- [21] S. Rangi and Y. Jain, Sheilza and Arya, “Utilization of energy storage devices with optimal controller for multi-area hydro-hydro power system under deregulated environment,” *Sustainable Energy Technologies and Assessments*, vol. 52, pp. 102–191, 2022,.
- [22] G. Tu, Y. Li, and J. Xiang, “Sliding mode control of energy storage systems for reshaping the accelerating power of synchronous generators,” *IEEE Transactions on Power Systems*, 2022.
- [23] Z. Wang and J. Wang, “A novel finite-time control scheme for enhancing smart grid frequency stability and resilience,” *IEEE Transactions on Smart Grid*, vol. 10, no. 6, pp. 6538–6551, 2019.
- [24] I. Kiaei and S. Lotfifard, “Tube-based model predictive control of energy storage systems for enhancing transient stability of power systems,” *IEEE Transactions on Smart Grid*, vol. 9, no. 6, pp. 6438–6447, 2017.

- [25] Y. Zhu, C. Liu, K. Sun, D. Shi, and Z. Wang, “Optimization of battery energy storage to improve power system oscillation damping,” *IEEE Transactions on Sustainable Energy*, vol. 10, no. 3, pp. 1015–1024, 2018.
- [26] K. M. Cheema, “A comprehensive review of virtual synchronous generator,” *International Journal of Electrical Power & Energy Systems*, vol. 120, page no. 106006, 2020.
- [27] A. Tayyebi, D. Groß, A. Anta, F. Kupzog, and F. Dörfler, “Frequency stability of synchronous machines and grid-forming power converters,” *IEEE Journal of Emerging and Selected Topics in Power Electronics*, vol. 8, no. 2, pp. 1004–1018, 2020.
- [28] M. Saeedian, R. Sangrody, M. Shahparasti, S. Taheri, and E. Pouresmaeil, “Grid-following DVI-based converter operating in weak grids for enhancing frequency stability,” *IEEE Transactions on Power Delivery*, vol. 37, no. 1, pp. 338–348, 2021.
- [29] X. Zhou, S. Cheng, X. Wu, and X. Rao, “Influence of photovoltaic power plants based on VSG technology on low frequency oscillation of multi-machine power systems,” *IEEE Transactions on Power Delivery*, vol. 37, no. 6, pp. 5376–5384, 2022.
- [30] P. Sun, J. Yao, Y. Zhao, X. Fang, and J. Cao, “Stability assessment and damping optimization control of multiple grid-connected virtual synchronous generators,” *IEEE Transactions on Energy Conversion*, vol. 36, no. 4, pp. 3555–3567, 2021.
- [31] Y. Li, L. Fan, and Z. Miao, “Wind in weak grids: Low-frequency oscillations, sub-synchronous oscillations, and torsional interactions,” *IEEE Transactions on Power Systems*, vol. 35, no. 1, pp. 109–118, 2019.
- [32] X. Wang, Weiyu and Shi, G. Wu, and Y. Cao, “Interaction between grid-forming converters with AC Grids and damping improvement based on loop shaping,” *IEEE Transactions on Power Systems*, 2023.
- [33] W. Du, Q. Fu, and a. F. Wang, “Power system small-signal angular stability affected by virtual synchronous generators,” *IEEE Transactions on Power Systems*, vol. 34, no. 4, pp. 3209–3219, 2019.

- [34] M. Chen, D. Zhou, and F. Blaabjerg, “Active power oscillation damping based on acceleration control in paralleled virtual synchronous generators system,” *IEEE Transactions on Power Electronics*, vol. 36, no. 8, pp. 9501–9510, 2021.
- [35] M. Yang, Y. Wang, S. Chen, X. Xiao, and Y. Li, “Comparative Studies on Damping Control Strategies for Virtual Synchronous Generators,” *IEEE Transactions on Power Delivery*, vol. 39, no. 2, pp. 0885–8977, 2023.
- [36] Y. Yu, S. K. Chaudhary, G. D. A. Tinajero, L. Xu, N. N. B. A. Bakar, J. C. Vasquez, and J. M. Guerrero, “A reference-feedforward-based damping method for virtual synchronous generator control,” *IEEE Transactions on Power Electronics*, vol. 37, no. 7, pp. 7566–7571, 2022.
- [37] Z. Shuai, W. Huang, Z. J. Shen, A. Luo, and Z. Tian, “Active power oscillation and suppression techniques between two parallel synchronverters during load fluctuations,” *IEEE Transactions on Power Electronics*, vol. 35, no. 4, pp. 4127–4142, 2019.
- [38] Z. Wang, Y. Chen, X. Li, Y. Xu, C. Luo, Q. Li, and Y. He, “Active power oscillation suppression based on decentralized transient damping control for parallel virtual synchronous generators,” *IEEE Transactions on Smart Grid*, vol. 14, no. 4, pp. 2582–2592, 2022.
- [39] Y. a. I. T. Shintai, Toshinobu and Miura, “Oscillation damping of a distributed generator using a virtual synchronous generator,” *IEEE Transactions on Power Delivery*, vol. 29, no. 2, pp. 668–676, 2014.
- [40] M. Ebrahimi, S. A. Khajehoddin, and M. Karimi-Ghartemani, “An improved damping method for virtual synchronous machines,” *IEEE Transactions on Sustainable Energy*, vol. 10, no. 3, pp. 1491–1500, 2019.
- [41] H. Ye, W. Pei, L. Kong, and T. An, “Low-order response modeling for wind farm-MTDC participating in primary frequency controls,” *IEEE Transactions on Power Systems*, vol. 34, no. 2, pp. 942–952, 2018.
- [42] M. Zhao, H. Yin, Y. Xue, X.-P. Zhang, and Y. Lan, “Coordinated damping control design for power system with multiple virtual synchronous generators based on

- prony method,” *IEEE Open Access Journal of Power and Energy*, vol. 8, pp. 316–328, 2021.
- [43] T. Xue, J. Zhang, and S. Bu, “Inter-area oscillation analysis of power system integrated with virtual synchronous generators,” *IEEE Transactions on Power Delivery*, vol. 39, no. 3, pp. 0885–8977, 2024.
- [44] W. Yao, L. Jiang, J. Wen, Q. Wu, and S. Cheng, “Wide-area damping controller of FACTS devices for inter-area oscillations considering communication time delays,” *IEEE Transactions on Power Systems*, vol. 29, no. 1, pp. 318–329, 2013.
- [45] R. Yousefian, R. Bhattarai, and S. Kamalasadani, “Transient stability enhancement of power grid with integrated wide area control of wind farms and synchronous generators,” *IEEE Transactions on Power Systems*, vol. 32, no. 6, pp. 4818–4831, 2017.
- [46] R. Shah, N. Mithulananthan, and K. Y. Lee, “Large-scale PV plant with a robust controller considering power oscillation damping,” *IEEE Transactions on Energy Conversion*, vol. 28, no. 1, pp. 106–116, 2012.
- [47] M. Sarkar and B. Subudhi, “Fixed low-order synchronized and non-synchronized wide-area damping controllers for inter-area oscillation in power system,” *International Journal of Electrical Power & Energy Systems*, vol. 113, page no. 582596, 2019.
- [48] M. Darabian and A. Bagheri, “Design of adaptive wide-area damping controller based on delay scheduling for improving small-signal oscillations,” *International Journal of Electrical Power & Energy Systems*, vol. 133, page no. 107224, 2021.
- [49] F. Wilches-Bernal, R. H. Byrne, and J. Lian, “Damping of inter-area oscillations via modulation of aggregated loads,” *IEEE Transactions on Power Systems*, vol. 35, no. 3, pp. 2024–2036, 2019.
- [50] R. Xie, I. Kamwa, and C. Chung, “A novel wide-area control strategy for damping of critical frequency oscillations via modulation of active power injections,” *IEEE Transactions on Power Systems*, vol. 36, no. 1, pp. 485–494, 2020.

- [51] T. Surinkaew and I. Ngamroo, “Adaptive signal selection of wide-area damping controllers under various operating conditions,” *IEEE Transactions on Industrial Informatics*, vol. 14, no. 2, pp. 639–651, 2017.
- [52] H. Xu, X. Fang, J. Yao, P. Sun, Y. Zhao, and J. Cao, “Damping optimization control for small-signal stability of power system with VSGs under multiple operating conditions,” *CSEE Journal of Power and Energy Systems*, 2024.
- [53] M. M. Radwan, A. M. Azmy, G. E. Ali, and A. E. ELGebaly, “Optimal design and control loop selection for a STATCOM wide-area damping controller considering communication time delays,” *International Journal of Electrical Power & Energy Systems*, vol. 149, page no. 109056, 2023.
- [54] Y. Nie, T. Liu, Z. Wang, and Y. Zhao, “Wide-area damping power system control based on robust self-triggered model predictive control,” *International Journal of Electrical Power & Energy Systems*, vol. 141, page no. 108194, 2022.
- [55] I. Zenelis and X. Wang, “A model-free sparse wide-area damping controller for inter-area oscillations,” *International Journal of Electrical Power & Energy Systems*, vol. 136, page no. 107609, 2022.
- [56] K. Kumar, A. Prakash, P. Singh, and S. Parida, “Large-scale solar PV converter based robust wide-area damping controller for critical low frequency oscillations in power systems,” *IEEE Transactions on Industry Applications*, vol. 59, no. 4, pp. 4868–4879, 2023.
- [57] M. Maherani, I. Erlich, and G. Krost, “Fixed order non-smooth robust  $H_\infty$  wide area damping controller considering load uncertainties,” *International Journal of Electrical Power & Energy Systems*, vol. 115, page no. 105423, 2020.
- [58] M. Li and Y. Chen, “A wide-area dynamic damping controller based on robust  $H_\infty$  control for wide-area power systems with random delay and packet dropout,” *IEEE Transactions on Power Systems*, vol. 33, no. 4, pp. 4026–4037, 2017.
- [59] J. Nan, W. Yao, J. Wen, Y. Peng, J. Fang, X. Ai, and J. Wen, “Wide-area power oscillation damper for DFIG-based wind farm with communication delay and packet

- dropout compensation,” *International Journal of Electrical Power & Energy Systems*, vol. 124, page no. 106306, 2021.
- [60] A. Prakash, R. K. Tiwari, K. Kumar, and S. Parida, “Interacting multiple model strategy based adaptive wide-area damping controller design for wind farm embedded power system,” *IEEE Transactions on Sustainable Energy*, vol. 14, no. 2, pp. 962–973, 2022.
- [61] M. E. Bento, “A hybrid particle swarm optimization algorithm for the wide-area damping control design,” *IEEE Transactions on Industrial Informatics*, vol. 18, no. 1, pp. 592–599, 2021.
- [62] Y. Zhao, W. Yao, C.-K. Zhang, X. Ai, and J. Wen, “Resilient wide-area damping control to mitigate strong cyber attack: A multiple-controller switching approach,” *IEEE Transactions on Smart Grid*, vol. 14, no. 3, pp. 2326–2337, 2022.
- [63] A. Kumar and M. Bhadu, “Wide-area damping control system for large wind generation with multiple operational uncertainty,” *Electric Power Systems Research*, vol. 213, page no. 108755, 2022.
- [64] P. W. Sauer, M. A. Pai, and J. H. Chow, *Power system dynamics and stability: with synchrophasor measurement and power system toolbox*. John Wiley & Sons, 2017.
- [65] H. Wang, W. Du *et al.*, *Analysis and damping control of power system low-frequency oscillations*, Springer, 2016.
- [66] L. Shi and F. Lee, Kwang Y and Wu, “Robust ESS-based stabilizer design for damping inter-area oscillations in multimachine power systems,” *IEEE Transactions on Power Systems*, vol. 31, no. 2, pp. 1395–1406, 2015.
- [67] T. Zhou, Z. Chen, B. Ren, S. Bu, and P. Wang, “Damping torque analysis of VSC-HVDC supplementary damping controller for small-signal stability,” *IEEE Access*, vol. 8, pp. 202 696–202 706, 2020.
- [68] H. Wang and F. Swift, “Multiple stabilizer setting in multi-machine power systems by the phase compensation method,” *International Journal of Electrical Power & Energy Systems*, vol. 20, no. 4, page no. 241246, 1998.

- [69] W. Du, H. Wang, J. Cao, and L. Li, Hai Feng and Xiao, “Application of the phase compensation method for the design of a DC/AC converter-based stabilizer to damp inter-area power oscillations,” *IEEE Transactions on Power Systems*, vol. 27, no. 3, pp. 1302–1310, 2012.
- [70] Z. Salehi, P. Karimaghaee, and M.-H. Khooban, “A new passivity preserving model order reduction method: conic positive real balanced truncation method,” *IEEE Transactions on Systems, Man, and Cybernetics: Systems*, vol. 52, no. 5, pp. 2945–2953, 2021.
- [71] A. C. Zolotas, B. Chaudhuri, I. M. Jaimoukha, and P. Korba, “A study on LQG/LTR control for damping inter-area oscillations in power systems,” *IEEE Transactions on Control Systems Technology*, vol. 15, no. 1, pp. 151–160, 2006.
- [72] W. Du, J. Bi, J. Cao, and H. Wang, “A method to examine the impact of grid connection of the DFIGs on power system electromechanical oscillation modes,” *IEEE Transactions on Power Systems*, vol. 31, no. 5, pp. 3775–3784, 2015.
- [73] J. Ma, H. Geng, L. Liu, X. Xi, and G. Yang, “Hybrid Modulated Active Damping Control for DFIG-Based Wind Farm Participating in Frequency Response,” *IEEE Transactions on Energy Conversion*, vol. 32, no. 3, pp. 1220–1230, 2017.
- [74] N. Kulkarni, S. Kamalasan, and S. Ghosh, “An integrated method for optimal placement and tuning of a power system stabilizer based on full controllability index and generator participation,” *IEEE Transactions on Industry Applications*, vol. 51, no. 5, pp. 4201–4211, 2015.
- [75] F. Milano, “An open source power system analysis toolbox,” *IEEE Transactions on Power Systems*, vol. 20, no. 3, pp. 1199–1206, 2005.
- [76] M. Abdeen, H. Li, S. Kamel, A. Khaled, M. El-Dabah, M. Kharrich, and H. F. Sindi, “A recent analytical approach for analysis of sub-synchronous resonance in doubly-fed induction generator-based wind farm,” *IEEE Access*, vol. 9, pp. 68 888–68 897, 2021.
- [77] P. C. Krause, O. Wasynczuk, S. D. Sudhoff, and S. D. Pekarek, *Analysis of electric machinery and drive systems*, John Wiley & Sons, 2013.

- [78] D. Wenjuan, B. Jingtian, W. Tong, and W. Haifeng, “Impact of grid connection of large-scale wind farms on power system small-signal angular stability,” *CSEE Journal of Power and Energy Systems*, vol. 1, no. 2, pp. 83–89, 2015.
- [79] K. Zhou and J. C. Doyle, *Essentials of robust control*, Prentice hall Upper Saddle River, NJ, vol. 104, 1998.
- [80] C. Canizares, T. Fernandes, E. Geraldi, L. Gerin-Lajoie, M. Gibbard, I. Hiskens, J. Kersulis, R. Kuiava, L. Lima, F. DeMarco *et al.*, “Benchmark models for the analysis and control of small-signal oscillatory dynamics in power systems,” *IEEE Transactions on Power Systems*, vol. 32, no. 1, pp. 715–722, 2016.
- [81] D. Chitara, K. R. Niazi, A. Swarnkar, and N. Gupta, “Cuckoo search optimization algorithm for designing of a multimachine power system stabilizer,” *IEEE Transactions on Industry Applications*, vol. 54, no. 4, pp. 3056–3065, 2018.
- [82] A. B. Iskakov, “Definition of state-in-mode participation factors for modal analysis of linear systems,” *IEEE Transactions on Automatic Control*, vol. 66, no. 11, pp. 5385–5392, 2020.
- [83] J. Qi, Q. Wu, Y. Zhang, G. Weng, and D. Zhou, “Unified residue method for design of compact wide-area damping controller based on power system stabilizer,” *Journal of Modern Power Systems and Clean Energy*, vol. 8, no. 2, pp. 367–376, 2020.
- [84] D. Bazargan, S. Filizadeh, and A. M. Gole, “Stability analysis of converter-connected battery energy storage systems in the grid,” *IEEE Transactions on Sustainable energy*, vol. 5, no. 4, pp. 1204–1212, 2014.
- [85] J. Sun, D. M. Mitchell, M. F. Greuel, P. T. Krein, and R. M. Bass, “Averaged modeling of PWM converters operating in discontinuous conduction mode,” *IEEE Transactions on Power Electronics*, vol. 16, no. 4, pp. 482–492, 2001.
- [86] N. Chaudhuri, B. Chaudhuri, R. Majumder, and A. Yazdani, *Multi-terminal direct-current grids: Modeling, analysis, and control*, John Wiley & Sons, 2014.
- [87] B. Wu, Y. Lang, N. Zargari, and S. Kouro, *Power conversion and control of wind energy systems*, John Wiley & Sons, 2011.

- [88] M. E. Bento, “Fixed low-order wide-area damping controller considering time delays and power system operation uncertainties,” *IEEE Transactions on Power Systems*, vol. 35, no. 5, pp. 3918–3926, 2020.
- [89] H. Wang, “Selection of robust installing locations and feedback signals of FACTS-based stabilizers in multi-machine power systems,” *IEEE transactions on Power Systems*, vol. 14, no. 2, pp. 569–574, 1999.
- [90] S. Skogestad and I. Postlethwaite, *Multivariable feedback control: analysis and design*, John Wiley & Sons, 2005.
- [91] P. Apkarian and D. Noll, “Nonsmooth  $H_\infty$  synthesis,” *IEEE Transactions on Automatic Control*, vol. 51, no. 1, pp. 71–86, 2006.
- [92] I. Hiskens, “IEEE PES task force on benchmark systems for stability controls,” *Technical report*, 2013.
- [93] C. O. Maddela and B. Subudhi, “Robust wide-area TCSC controller for damping enhancement of inter-area oscillations in an interconnected power system with actuator saturation,” *International Journal of Electrical Power & Energy Systems*, vol. 105, page no. 478487, 2019.
- [94] Y. Zuo, M. Paolone, and F. Sossan, “Effect of voltage source converters with electrochemical storage systems on dynamics of reduced-inertia bulk power grids,” *Electric Power Systems Research*, vol. 189, page no. 106766, 2020.
- [95] B. Chaudhuri and B. C. Pal, “Robust damping of multiple swing modes employing global stabilizing signals with a TCSC,” *IEEE Transactions on power systems*, vol. 19, no. 1, pp. 499–506, 2004.
- [96] Z. Xu, Z. Dong, and P. Zhang, “Probabilistic small signal analysis using monte carlo simulation,” *IEEE Power Engineering Society General Meeting*, pp. 1658–1664, 2005.
- [97] Y. Wang, C. Zhao, and C. Guo, “Comparison study of small-signal stability of MMC-HVDC system in different control modes,” *International Journal of Electrical Power & Energy Systems*, vol. 111, page no. 425435, 2019.

- [98] S. Ghosh, Y. J. Isbeih, and M. S. El Moursi, “Assessment of bus inertia to enhance dynamic flexibility of hybrid power systems with renewable energy integration,” *IEEE Transactions on Power Delivery*, vol. 38, no. 4, pp. 2372–2386, 2023.
- [99] S. Li, “Low-frequency oscillations of wind power systems caused by doubly-fed induction generators,” *Renewable Energy*, vol. 104, pp. 129–138, 2017.
- [100] T. Surinkaew and I. Ngamroo, “Inter-area oscillation damping control design considering impact of variable latencies,” *IEEE Transactions on Power Systems*, vol. 34, no. 1, pp. 481–493, 2018.
- [101] T. Surinkaew and I. Ngamroo, “Impact of variable time delay on oscillatory stability in power system with wind and solar farms using wide area damping control,” *IFAC-Papers OnLine*, vol. 52, no. 4, pp. 81–86, 2019.
- [102] L. Huang, H. Xin, and Z. Wang, “Damping low-frequency oscillations through VSC-HVDC stations operated as virtual synchronous machines,” *IEEE Transactions on Power Electronics*, vol. 34, no. 6, pp. 5803–5818, 2018.
- [103] Y. Wang, Q. Wu, W. Gong, and M. P. S. Gryning, “ $H_\infty$  Robust Current Control for DFIG-Based Wind Turbine Subject to Grid Voltage Distortions,” *IEEE Transactions on Sustainable Energy*, vol. 8, no. 2, pp. 816–825, 2016.

# Appendix-A

## IEEE 9-bus System Data

The details of the IEEE 9-bus system are taken from [64, 74]. The single-line diagram of the system is shown in Fig. A.1. Generator data, exciter data, transformer data and transmission line data are shown in Table A.1, Table A.2, Table A.3 and Table A.4, respectively.

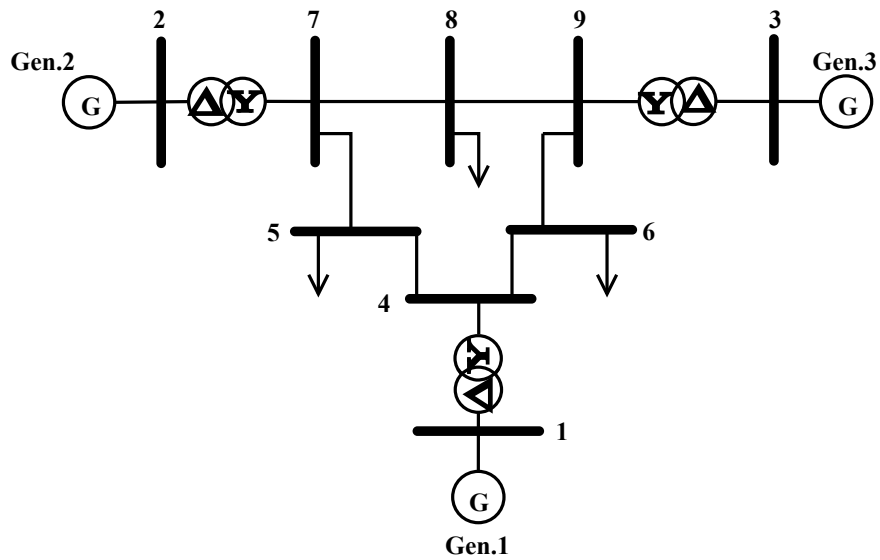

Figure A.1: Single line diagram of IEEE 9-bus power system.

Table A.1: Generator data (100 MVA Base)

Parameters	SG-1	SG-2	SG-3
$H(\text{sec})$	23.64	6.4	3.01
$X_d$ (p.u.)	0.146	0.895	1.312
$X'_d$ (p.u.)	0.060	0.119	0.181
$X_q$ (p.u.)	0.096	0.864	1.257
$X'_q$ (p.u.)	0.096	0.196	0.25
$T'_{do}$ (p.u.)	8.96	6.0	5.89
$T'_{qo}$ (p.u.)	0.31	0.535	0.6

Table A.2: Generator exciter data

Parameters	SG-1	SG-2	SG-3
$K_A$	20	20	20
$T_A$ (sec)	0.2	0.2	0.2
$K_E$	1.0	1.0	1.0
$T_E$ (sec)	0.314	0.314	0.314
$K_F$	0.063	0.063	0.063
$T_F$ (sec)	0.35	0.35	0.35

Table A.3: Transformer data

From Bus	To bus	Resistance, R (p.u.)	Reactance, X (p.u.)	Susceptance, B (p.u.)	Tape Ratio
1	4	0.0	0.0576	0.0	1.0
2	7	0.0	0.0625	0.0	1.0
3	9	0.0	0.0586	0.0	1.0

Table A.4: Transmission line data

From Bus	To bus	Resistance, R (p.u.)	Reactance, X (p.u.)	Susceptance, B (p.u.)
4	5	0.010	0.085	0.176
4	6	0.017	0.092	0.158
5	7	0.032	0.161	0.306
6	9	0.039	0.170	0.358
7	8	0.0085	0.072	0.149
8	9	0.011	0.1008	0.209



Table B.2: Generator exciter data

Parameters	SG-1	SG-2	SG-3	SG-4	SG-5
$K_A$	6.2	6.2	6.2	6.2	6.2
$T_A$ (sec)	0.05	0.05	0.05	0.05	0.05
$K_E$	1.0	1.0	1.0	1.0	1.0
$T_E$ (sec)	0.83	0.83	0.83	0.83	0.83
$K_F$	0.057	0.057	0.057	0.057	0.057
$T_F$ (sec)	0.5	0.5	0.5	0.5	0.5

Table B.3: Transformer data

From Bus	To Bus	Resistance, R (p.u.)	Reactance, X (p.u.)	Tap ratio
4	7	0.0	0.209	0.978
4	9	0.0	0.556	0.969
5	6	0.0	0.252	0.932
7	8	0.0	0.176	1.000
7	9	0.0	0.110	1.000

Table B.4: Transmission line data

From Bus	To Bus	Resistance, R (p.u.)	Reactance, X (p.u.)	Susceptance, B (p.u.)
1	2	0.0193	0.0591	0.0264
1	5	0.0540	0.2230	0.0246
2	3	0.0469	0.1979	0.0219
2	4	0.0581	0.1763	0.0187
3	4	0.0670	0.1710	0.0173
4	5	0.0133	0.0421	0.0064
6	11	0.0949	0.1989	—
6	12	0.1229	0.2558	—
6	13	0.0661	0.1302	—
9	10	0.0318	0.0845	—
9	14	0.1271	0.2703	—
10	11	0.0820	0.1920	—
12	13	0.2209	0.1998	—
13	14	0.1709	0.3480	—

# Appendix-C

## New England Ten Machine System Data

The details of the New England 39 bus system are taken from [92]. The single-line diagram of the system is shown in Fig. C.1. Generator data, exciter data, transformer data and transmission line data are shown in Table C.1, Table C.2, Table C.3 and Table C.4, respectively.

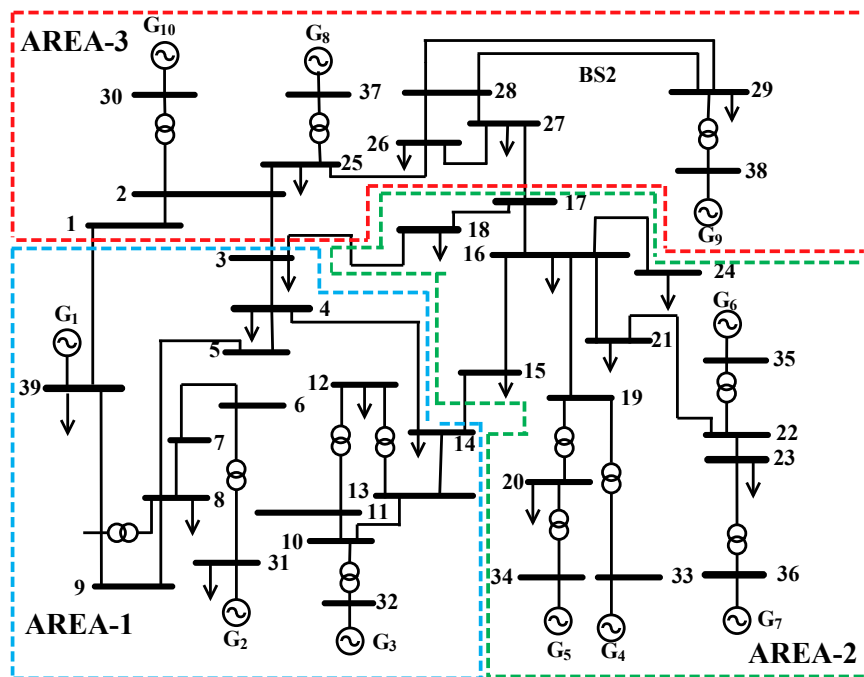

Figure C.1: Single line diagram of New England 39-bus system.

Table C.1: Generator data (1000 MVA Base)

Parameters	SG-1	SG-2	SG-3	SG-4	SG-5	SG-6	SG-7	SG-8	SG-9	SG-10
H(sec)	50	3.03	3.58	2.86	2.6	3.48	2.64	2.43	3.45	4.2
$X_d$ (p.u.)	0.2	2.95	2.495	2.62	6.7	2.54	2.95	2.9	2.106	1
$X'_d$ (p.u.)	0.06	0.697	0.531	0.436	1.32	0.5	0.49	0.57	0.57	0.31
$X_q$ (p.u.)	0.19	2.82	2.37	2.58	6.2	2.41	2.92	2.8	2.05	0.69
$X'_q$ (p.u.)	0.08	1.7	0.876	1.66	1.66	0.814	1.86	0.911	0.587	0.3
$T'_{do}$ (p.u.)	7.0	6.56	5.7	5.69	5.4	7.3	5.66	6.7	4.79	10.2
$T'_{qo}$ (p.u.)	0.7	1.5	1.5	1.5	0.44	0.4	1.5	0.41	1.96	1.5

Table C.2: Generator exciter data

Parameters	SG-2	SG-3	SG-4	SG-5	SG-6	SG-7	SG-8	SG-9	SG-10
$K_A$	6.2	5.0	5.0	40.0	5.0	40.0	5.0	40.0	5.0
$T_A$ (sec)	0.05	0.06	0.06	0.02	0.02	0.02	0.02	0.02	0.06
$K_E$	-0.633	-0.019	-0.052	1.0	-0.041	1.0	-0.047	1.0	-0.048
$T_E$ (sec)	0.405	0.500	0.500	0.785	0.471	0.730	0.528	1.400	0.250
$K_F$	0.057	0.080	0.080	0.030	0.754	0.030	0.085	0.030	0.040
$T_F$ (sec)	0.5	1.0	1.0	1.0	1.246	1.0	1.260	1.0	1.0

Table C.3: Transformer data

From Bus	To bus	Resistance, R (p.u.)	Reactance, X (p.u.)	Susceptance, B (p.u.)	Tape Ratio
12	11	0.0016	0.0435	0.0	1.006
12	13	0.0016	0.0435	0.0	1.006
6	31	0.0	0.0250	0.0	1.070
10	32	0.0	0.0200	0.0	1.070
19	33	0.0007	0.0142	0.0	1.009
20	34	0.0009	0.0180	0.0	1.009
22	35	0.0	0.0143	0.0	1.025
23	36	0.0005	0.0272	0.0	1.0
25	37	0.0006	0.0232	0.0	1.025
2	30	0.0	0.0181	0.0	1.025
29	38	0.0008	0.0156	0.0	1.025
19	20	0.0007	0.0138	0.0	1.060

Table C.4: Transmission line data

From Bus	To Bus	Resistance, R (p.u.)	Reactance, X (p.u.)	Susceptance, B (p.u.)
1	2	0.0035	0.0411	0.698
1	39	0.0010	0.0250	0.750
2	3	0.0013	0.0151	0.257
2	25	0.0070	0.0086	0.1460
3	4	0.0013	0.0213	0.2214
3	18	0.0011	0.0133	0.2138
4	5	0.0008	0.0128	0.1342
4	14	0.0008	0.0129	0.1382
5	6	0.0002	0.00026	0.0434
5	8	0.0008	0.0112	0.1476
6	7	0.0006	0.0092	0.1130
6	11	0.0007	0.0082	0.1389
7	8	0.0004	0.0046	0.0780
8	9	0.0023	0.0363	0.3804
9	39	0.0010	0.0250	1.2000
10	11	0.0004	0.0043	0.0729
10	13	0.0004	0.0043	0.0729
13	14	0.0009	0.0101	0.1723
14	15	0.0018	0.0217	0.3660
15	16	0.0009	0.0094	0.1710
16	17	0.0007	0.0089	0.1342
16	19	0.0016	0.0195	0.3040
16	21	0.0008	0.0135	0.2548
16	24	0.0003	0.0059	0.0680
17	18	0.0007	0.0082	0.1319
17	27	0.0013	0.0173	0.3216
21	22	0.0008	0.0140	0.2565
22	23	0.0006	0.0096	0.1846
23	24	0.0022	0.0350	0.3610
25	26	0.0032	0.0323	0.5130
26	27	0.0014	0.0147	0.2396
26	28	0.0043	0.0474	0.7802
26	29	0.0057	0.0625	1.0290
28	29	0.0014	0.0151	0.2490



# List of Publications

1. **Rohit Kumar**, Soumya. R. Mohanty, and M. K. Verma, “A robust damping control for battery energy storage integrated power systems to mitigate inter- area oscillations,” International Journal of Electrical Power & Energy Systems, vol. 157, paper no. 109885, 2024.
2. **Rohit Kumar**, Soumya. R. Mohanty, and Mitresh Kumar Verma, “Robust damping control for integrated wind turbine power networks during low inertia condition,” International Journal of Circuit Theory and Applications, 2024, Doi:10.1002/cta.3991.
3. **Rohit Kumar**, Soumya. Mohanty, and M. K. Verma, “Design and optimal location of power system stabilizer in the multi-machine power network,” IETE Journal of Research, vol. 70, no. 3, pp. 2782-2801, 2024.
4. **Rohit Kumar**, Soumya. R. Mohanty, and Mitresh Kumar Verma, “Enhancing Damping of Low-Frequency Oscillations in Power Networks through Energy Storage System-Based Controller,” International Journal of Circuit Theory and Applications, (Accepted).
5. **Rohit Kumar**, Soumya. R. Mohanty, and M. K. Verma, “ Robust Damping Control Scheme for VSG-Enabled Inverter-Based Resources in Low Inertia Bus Power Networks to Mitigate Low-Frequency Oscillations,”( Work under progress).