

Chapter 5

UN-INTENTIONAL ISLANDING DETECTION SCHEME IN V2G ENVIRONMENT FOR PROTECTION OF ELECTRIC VEHICLES CHARGING STATION

5.1 INTRODUCTION

In order to protect Distributed Generation (DG), islanding detection is an indispensable requirement. A charging station with Electric Vehicles (EVs) in Vehicle-To-Grid (V2G) mode can serve as an inverter-based DG and needs to be disconnected from the grid in case of islanding of the microgrid. This work provides an improved hybrid Islanding Detection Scheme (IDS) to protect Electric Vehicle Charging Station (EVCS) under the un-intentional islanding of the microgrid. The hybrid scheme uses Modified-Sandia Frequency Shift (M-SFS) as the active and Fast Rate of Change of Frequency (FROCOF) as the passive method. The FROCOF relay activates the M-SFS in case islanding is suspected, and then, M-SFS ascertains the islanding event. The efficacy of the conventional SFS method heavily relies upon the design parameters, initial chopping fraction (cf_0), and positive-feedback gain (k). The modification in the SFS method eliminates the requirement of cf_0 and guarantees islanding detection at lower values of k . The proposed IDS is tested for the IEEE Std. 1547-2018 [104] and UL-1741 Std. [105] anti-islanding requirements. The effectiveness of the proposed scheme is also demonstrated under different non-islanding events, different load quality factors, and multiple DG operations. It is observed that the proposed scheme is able to discriminate between islanding and non-islanding events and disconnects EVCS under islanding events only.

5.2 SYSTEM DESCRIPTION

The single-line diagram of the test system [106] used for the studies as per the anti-islanding requirements of IEEE Std. 1547-2018 and UL-1741 Std. is shown in Fig. 5.1. The main grid is modelled as a three-phase voltage source behind the impedance, Z_G (with resistance R_G and reactance L_G). Electric Vehicles at EVCS are modelled as inverter-based DG, which are connected through DC/AC converter (bi-directional EV charger) operating at approximately unity power factor to corresponding charging points. A constant parallel RLC branch is used to model the load. The main grid is connected to the load and DG at the Point of Common Coupling (PCC) through a circuit breaker (C.B.1). The series filter L_f with its equivalent resistance R_f is used to filter out the current harmonics introduced by the switching of the inverter. The EVCS is connected to PCC through a circuit breaker (C.B.2) and series filter. The parameters of the test system are shown in Table 5.1. In this table K_p and K_i represent the gain of the proportional and integral controller, respectively. Identical Proportional-Integral (PI) controllers with $K_p = 2$ and $K_i = 400$ have been used to control the inverter d-axis as well as q-axis reference currents I_d and I_q in this work.

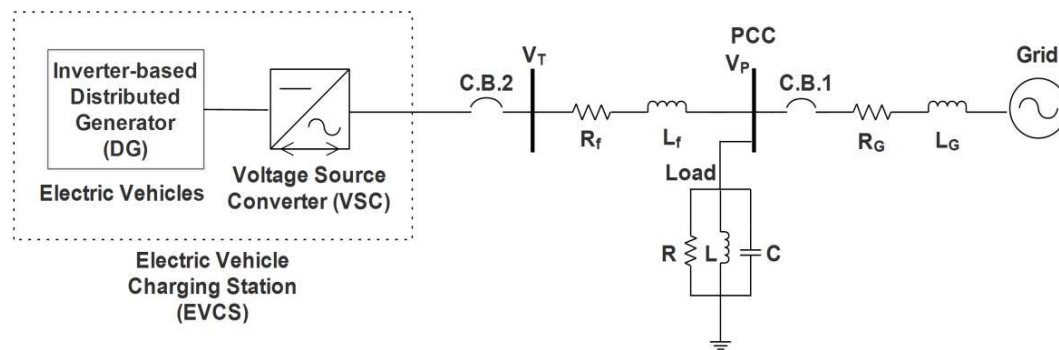

Fig. 5.1 Single-line diagram of the test system.

Table 5.1 Test system parameters.

System Parameters	Value
DG Rated Output Power	240kW
PWM Modulator Carrier Frequency	1.98kHz
Nominal DC link Voltage	480V
Nominal PCC Voltage (L-L RMS)	25kV
Nominal Frequency	60Hz
Grid Resistance (R_G)	1.6142 Ω
Grid Inductance (L_G)	14.7mH
Filter Resistance (R_f)	0.000374 Ω
Filter Inductance (L_f)	99.35 μ H
DG inverter controller parameters	I_d controller constants $K_p=2, K_i=400$
	I_q controller constants $K_p=2, K_i=400$

5.3 PROBLEM DEFINITION AND FORMULATION

Active and Passive techniques of islanding detection have their own advantages and shortcomings. Active techniques can accurately predict islanding while eliminating Non-Detection Zone (NDZ), but they continuously inject disturbance signal into the system, thereby degrading the Power Quality (PQ). On the contrary, passive techniques largely take measurements at PCC and hence, don't have any impact on the system's PQ.

However, these techniques have a large NDZ. Hence, a hybrid IDS is proposed in this work to overcome the limitations of both the techniques.

5.3.1 Sandia Frequency Shift (SFS) Method

The method, Sandia Frequency Shift (SFS) [107], for islanding detection was proposed by the Sandia National Laboratories, USA. In this method, a small perturbation is intentionally introduced in the AC output current of the inverter. Under the normal operating condition, the perturbation is defined in terms of chopping fraction as:

$$cf = cf_0 + k(f - f_{nom}) \quad (5.1)$$

where, cf is the chopping fraction, cf_0 is the zero-frequency error chopping fraction, k is the positive-feedback gain, f is the islanded PCC voltage frequency and f_{nom} is the nominal frequency in grid-connected mode at PCC, respectively.

When the microgrid is connected to the main grid, the frequency at PCC is regulated by the main grid, and the frequency deviation from its nominal value, i.e., $(f - f_{nom})$ is near to zero. This results in chopping fraction $cf = cf_0$. However, as soon as the microgrid separates from the main grid, cf starts increasing as a result of increased frequency deviation. The increase in chopping fraction increases the phase angle for the inverter output current, $\delta_{i,DG}$ as per:

$$\delta_{i,DG} = \frac{\pi}{2}(cf_0 + k(f - f_{nom})) \quad (5.2)$$

This results in a positive feedback loop for an intentional increase in the frequency till it crosses the relays Under Frequency/Over Frequency (UF/OF) threshold limits. The block diagram of the control scheme of the conventional SFS method for islanding detection is shown in Fig. 5.2.

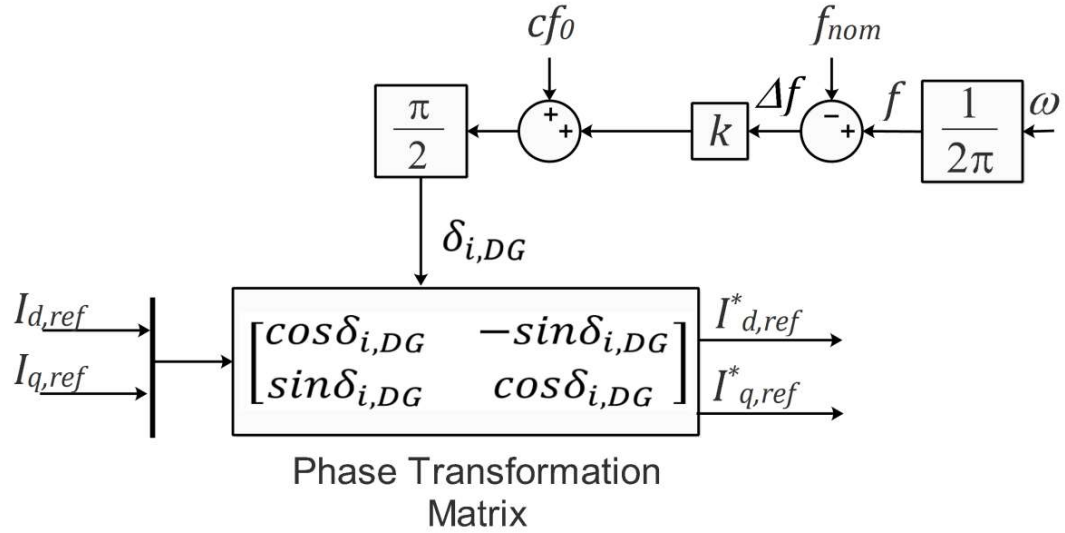

Fig. 5.2 Conventional SFS block diagram in the control interface scheme.

5.3.2 Proposed Modified Sandia Frequency Shift (M-SFS) Method

In the proposed M-SFS based active method, a modification in the linear positive-feedback gain is introduced. The frequency deviation gain product block is replaced to have square root adjusted behaviour. The proposed modification block comprises of a signed square root $sign(u) \times \sqrt{|u|}$ with $u = k(f - f_{nom})$. The modified equation of the phase angle for the inverter output current, $\delta_{i,DG}$ for the operation of the M-SFS method can be expressed as:

$$\delta_{i,DG} = \frac{\pi}{2} (cf_0 + sign[k(f - f_{nom})] \times \sqrt{|k(f - f_{nom})|}) \quad (5.3)$$

It can be inferred from equation (5.3) that the increase/decrease in Phase-Locked Loop (PLL) measured frequency at PCC results in a rapid change in the inverter phase angle that, in turn, alters the inverter output current until the frequency reaches OF/UF relay threshold, and can provide faster islanding detection than conventional SFS utilizing linear feedback gain. It is important to highlight that the proposed M-SFS doesn't aim at

adjusting the feedback gain or the initial chopping fraction, and hence, the scheme doesn't introduce additional disturbances into the system in the steady state.

The phase angle of the load current, δ_{load} is represented as a function of the load quality factor Q_f , load resonant frequency f_0 and frequency of PCC voltage under islanding f as [108]:

$$\delta_{load} = -\tan^{-1}\left[Q_f \left(\frac{f_0}{f} - \frac{f}{f_0}\right)\right] \quad (5.4)$$

Under the steady-state islanded operating condition, the inverter output current phase angle given by equation (5.3) is equated with the load current phase angle given by equation (5.4), and the equilibrium criteria is as follows:

$$f_0^2 + \frac{f}{Q_f} \tan\left(\frac{\pi}{2}(cf_0 + \sqrt{k(f - f_{nom})})\right) f_0 - f^2 = 0 \quad (5.5)$$

The NDZ of the proposed scheme depends upon system parameters f, f_0, f_{nom} and on the parameters of the M-SFS scheme cf_0, k . The equilibrium point given by equation (5.5) must be unstable to ensure islanding detection, and the NDZ can be completely eliminated as per the inequality constraint given by:

$$\frac{d\delta_{load}}{df} < \frac{d\delta_{i,DG}}{df} \quad (5.6)$$

where,

$$\frac{d\delta_{load}}{df} = \frac{Q_f \left(\frac{f_0}{f^2} + \frac{1}{f_0}\right)}{1 + Q_f^2 \left(\frac{f_0}{f} - \frac{f}{f_0}\right)^2} \quad (5.7)$$

and,

$$\frac{d\delta_{i,DG}}{df} = \frac{\pi}{4} \frac{k}{\sqrt{k(f - f_{nom})}} \quad (5.8)$$

The positive-feedback gain k value in equation (5.3) can be obtained from the slope criterion in (5.7) and (5.8) that ensures the frequency drift outside of OF/UF relay threshold. The inequality constraint for positive-feedback gain can be expressed as:

$$k > \left[\frac{4}{\pi} \frac{Q_f \left(\frac{f_0 + 1}{f^2 + f_0} \right)}{1 + Q_f^2 \left(\frac{f_0 - f}{f} \right)^2} \right]^2 (f - f_{nom}) \quad (5.9)$$

The maximum value of Right Hand Side (RHS) in equation (5.8) is obtained at $f = f_0$ and while designing M-SFS, the value of f_0 is set at 59.4Hz (under frequency threshold limit). Thus, the expression is reduced into:

$$k > \left[\frac{8}{\pi} \frac{Q_f}{f_0} \right]^2 (f_0 - f_{nom}) \quad (5.10)$$

The M-SFS scheme proposed in this work requires a lower value of positive feedback gain k for islanding detection compared to the M-SFS scheme suggested in [109]. For example, with the proposed M-SFS technique, a load quality factor of 7 leads to the minimum required feedback gain $k > 0.054$ to ensure islanding detection with no NDZ, while the M-SFS technique suggested in [109], having $k > 4Q_f/\pi f_0$ with $Q_f = 7$ and $f_0 = 59.4\text{Hz}$ requires $k > 0.15$.

The modification in the conventional SFS scheme in the proposed M-SFS scheme guarantees islanding detection at a much lower value of feedback gain. Thereby, the M-SFS technique eliminates false islanding detection and reduces the PQ disturbances.

5.3.3 Fast Rate of Change of Frequency (FROCOF) Method

The ROCOF is a passive IDS that relies upon computing change in frequency (Δf) from the nominal value over a predefined number of cycles. The tripping of the utility breaker leads to a high (df/dt) of the PCC voltage. In such a condition, the islanding is confirmed when the PCC voltage (df/dt) is higher than the set relay threshold (β) for a predefined number of cycles.

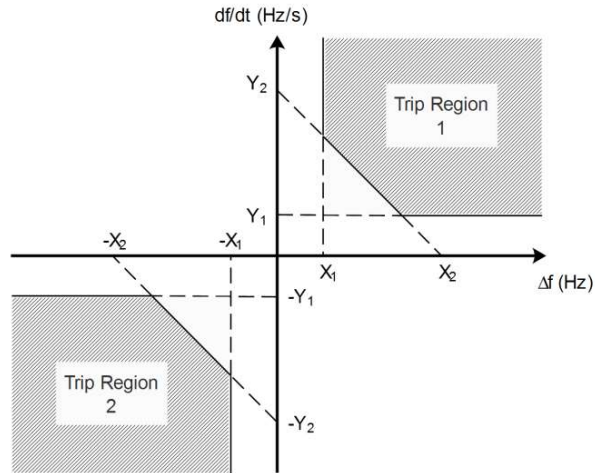

Fig. 5.3 FROCOF element characteristics.

The FROCOF element [110] utilizes the change in frequency (Δf) in addition to the rate of change of frequency (df/dt) as shown in Fig. 5.3. In the characteristics, X_1 and Y_1 are the lower limits of the change in frequency and rate of change of frequency while X_2 and Y_2 are the values with the rate of change of frequency set to zero and the change in frequency set to zero. Under steady-state conditions, the locally generated real power and real power imported from the utility matches the local real power demand. Thus, the frequency is close to the nominal value, and the operating point in the Δf versus df/dt plane is near to the origin. During the separation from the utility, the operating point shifts to either of the Trip Regions depending upon the generation-load mismatch. Further, the time taken by the FROCOF element to move into Trip Region depends upon the degree of power mismatch, i.e., faster response for a higher degree of mismatch.

5.3.4 Proposed hybrid IDS

The proposed hybrid scheme utilizes M-SFS as an active and FROCOF as the passive method. The proposed hybrid IDS extracts the best features using a combination of these two methods. The limitation of the active method is its continuous injection of disturbances into the grid, thereby degrading the power quality, which is overcome by

the FROCOF relay that activates M-SFS only when the islanding is suspected. In the block diagram in Fig. 5.4, PLL measures the frequency of the voltage at PCC. A large enough variation in Δf and df/dt may cause the relay operating point to fall into either of the trip regions. The FROCOF relay then sends the trip signal to activate the M-SFS scheme, which results in a new inverter reference current transformed using phase-angle transformation $I_{d,ref}^*$ and $I_{q,ref}^*$.

On the other hand, during normal operating conditions, the FROCOF relay's operating point lies outside the trip region, and no signal is sent to activate the M-SFS scheme. Thus, there is no impact of M-SFS on the power quality of the system during steady-state operation.

Islanding detection using the FROCOF method under closely matched local load and generation is difficult. An increase in the area under the trip region, which is equivalent to lowering the relay threshold value, may cause frequent undesirable tripping of DG, while reducing the area under the trip region may lead to non-detection of the islanding event. In the proposed hybrid method, the FROCOF method is utilized to suspect whereas the M-SFS method confirms the islanding detection events and hence, the relay threshold is set to lower possible value so as to activate M-SFS during islanding event under closely matched local load and generation conditions.

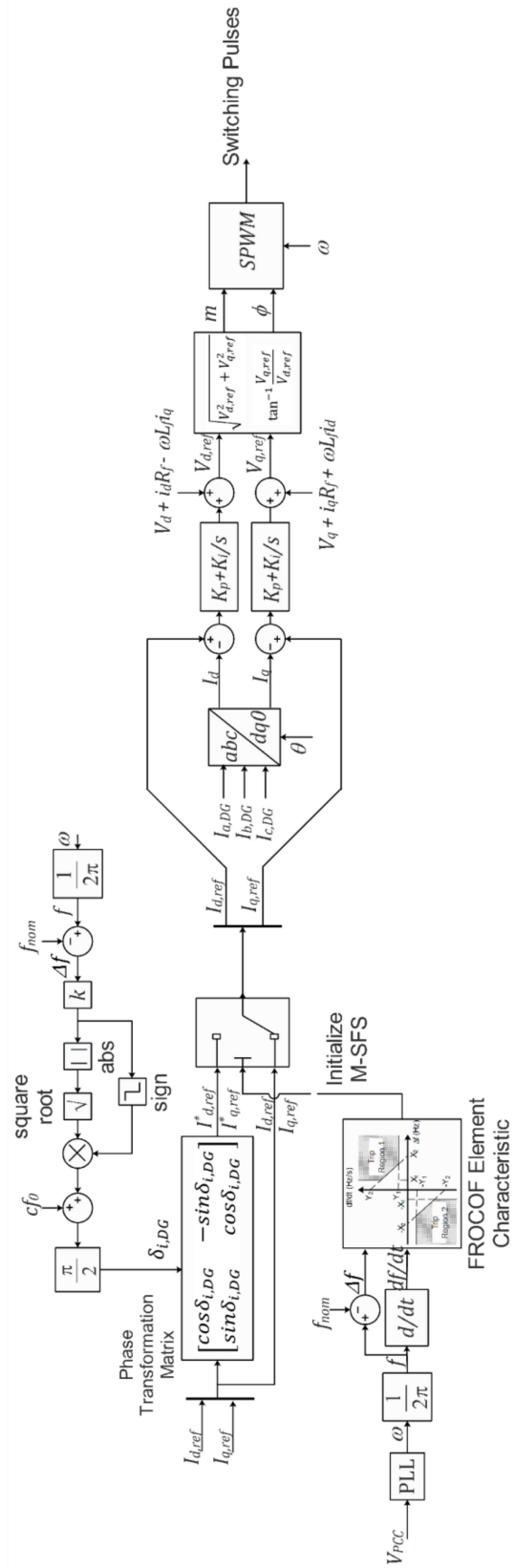

Fig. 5.4 Block diagram of the proposed hybrid IDS.

5.4 SIMULATION RESULTS AND DISCUSSION

The power system model depicted in Fig. 5.1 is simulated using MATLAB/Simulink with the parameter values given in Table 5.1. The performance of the proposed hybrid method is evaluated under different system operating conditions, such as various islanding events with different active and reactive power mismatch conditions and non-islanding events, i.e., grid-connected load switching, motor and capacitor switching, and three-phase fault occurrence, system operation with different X/R ratios and different load quality factor values. As discussed in the previous section, the performance of the M-SFS method depends upon two parameters of the scheme, i.e., initial chopping fraction (cf_0) and positive-feedback gain (k). The impact of higher values of k is more profound than cf_0 on the efficacy of the proposed scheme. Hence, the initial chopping fraction is set at zero. Furthermore, by eliminating cf_0 , the effect of M-SFS on the power quality disturbances is reduced during its active period. However, the higher values of k can deviate the frequency from the normal range for different loading conditions and may cause DG to become unstable even under grid-connected mode. Therefore, choosing a safe value that guarantees stable DG operation in grid-connected mode and fast and efficient islanding detection is crucial. The value of k_{M-SFS} (positive feedback gain k for M-SFS method) is determined in accordance with equation (5.10) and set at 0.085.

5.4.1 Proposed hybrid IDS operation under different Active Power Mismatch (APM) and Reactive Power Mismatch (RPM)

In this section, the efficiency of the proposed hybrid method is assessed during grid-connected and islanded conditions. The suggested method should be able to operate under various active and reactive power mismatches between DG power output and the local demand of the microgrid conditions. To test that, the active power of the load is varied in

the range of 85% to 115% of DG's rated power. Similarly, the reactive power is varied in the range of 85% to 115% of the rated reactive power output of DG. In order to evaluate the operation of the proposed islanding detection method within the system for study under islanded conditions, seven samples of the simulation results are presented in this section for Active Power Mismatch (APM) and Reactive Power Mismatch (RPM). The seven cases of APM considered are: (i) 5% increase in active power (+5% APM), (ii) 10% increase in active power (+10% APM), (iii) 15% increase in active power (+15% APM), (iv) 5% decrease in active power (-5% APM), (v) 10% decrease in active power (-10% APM), (vi) 15% decrease in active power (-15% APM), and (vii) no change (0% mismatch) in active power (ZPM). The seven cases of reactive power mismatch considered are: (i) 5% increase in reactive power (+5% RPM), (ii) 10% increase in reactive power (+10% RPM), (iii) 15% increase in reactive power (+15% RPM), (iv) 5% decrease in reactive power (-5% RPM), (v) 10% decrease in reactive power (-10% RPM), (vi) 15% decrease in reactive power (-15% RPM), and (vii) no change (0% mismatch) in reactive power (ZPM).

The plots of frequency versus time for seven cases of APM in the presence of proposed hybrid IDS are shown in Fig. 5.5, whereas frequency versus time plots for seven cases of RPM in the presence of hybrid IDS are shown in Fig. 5.6.

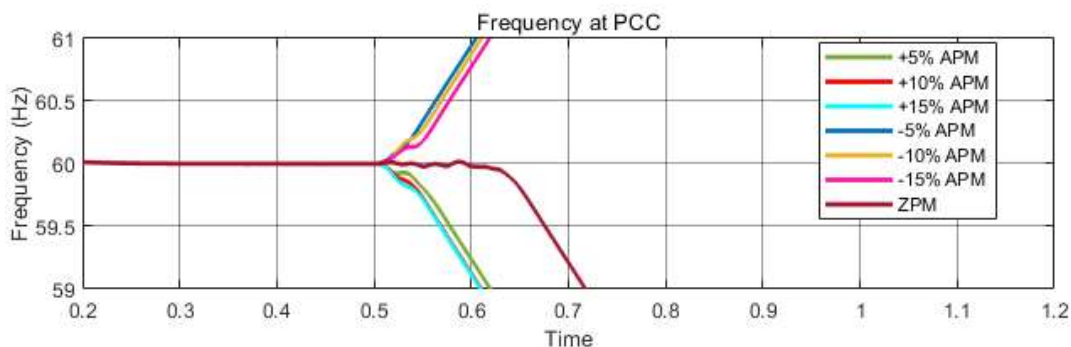

Fig. 5.5 PCC frequency for the system under different APM conditions equipped with the proposed hybrid method.

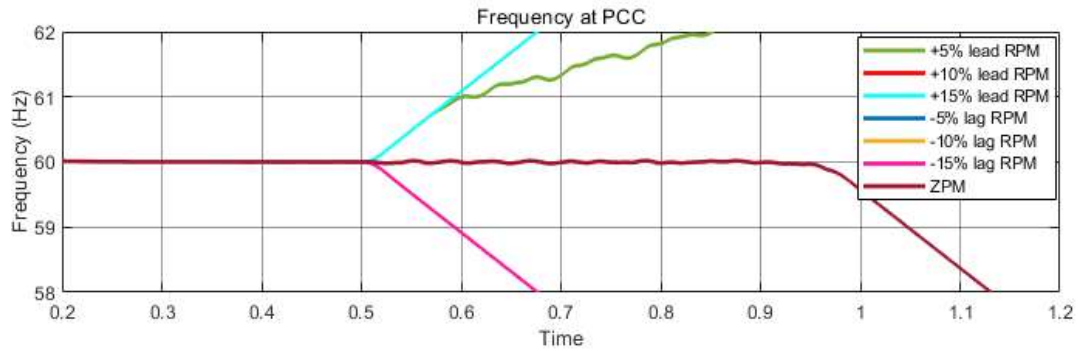

Fig. 5.6 PCC frequency for the system under different RPM conditions equipped with the proposed hybrid method.

It is evident from Fig. 5.5 that the PCC frequency is at the nominal value, and DG operates steadily under normal operating conditions upto 0.5 seconds (s). The frequency, however, deviates from the under-frequency and over-frequency thresholds (considered in this work as 59.4Hz and 60.6Hz, respectively) when islanding occurs at 0.5s and DG fails to maintain stable operation as a consequence of frequency deviations. As can be observed, the frequency deviates from the nominal value faster when there is a large active power mismatch between the load and DG. The similar outcome is noticeable in scenarios when the load and DG have reactive power mismatches, as illustrated in Fig. 5.6.

Another case is simulated with different power mismatch conditions in the absence of the proposed hybrid IDS. The islanding event is simulated at 0.5s, and as can be seen from Fig. 5.7, for the case of ZPM and all other cases of APM, the frequency lies well within the limits of the relay threshold and hence, islanding cannot be detected. It can be inferred from the series of simulation results under various active/reactive power mismatch conditions that the proposed hybrid IDS effectively ascertains islanding events under all cases of test conditions.

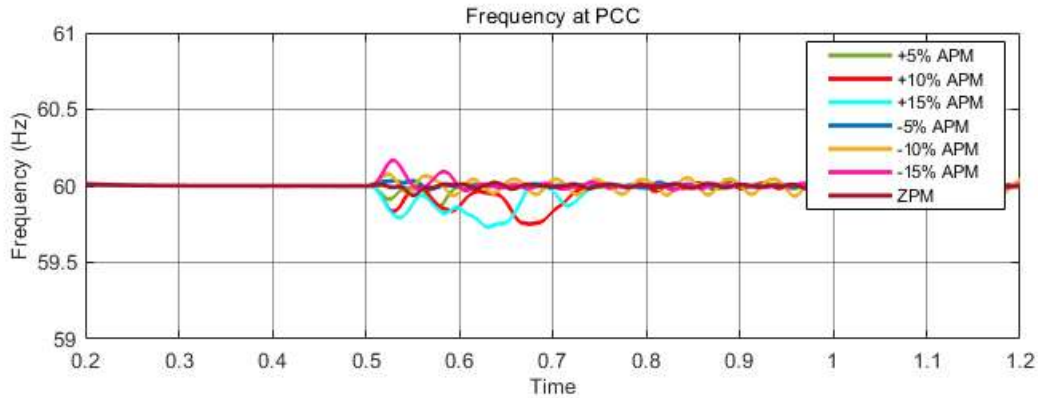

Fig. 5.7 PCC frequency for the system without the proposed hybrid method.

5.4.2 Operation under different load switching

In the load-switching conditions of the grid-connected mode of operation, the proposed hybrid approach is tested in this section. The test aims to confirm that the proposed IDS approach is not sensitive to load switching when operating DGs in grid-connected mode. The test process involves an additional load switched ON at 0.5s and switched OFF at 1s. To characterize the load-switching events, three distinct cases are taken into account:

Case 1) The base load is increased by 150 kVA, 0.8 lag power factor (pf) at 0.5s, which is switched OFF at 1s.

Case 2) The base load is increased by 150 kVA, 0.8 (pf lead) at 0.5s, which is switched OFF at 1s.

Case 3) The base load is increased by 150 kVA, unity pf at 0.5s, which is switched OFF at 1s.

With unity pf, the base load is set at 240 kW active power. In the grid-connected mode of operation, under load-switching conditions, the frequency is shown to be in the permissible range by the proposed hybrid IDS (Fig. 5.8) when the extra load is switched

ON and OFF. In other words, the proposed hybrid IDS does not provide a false trip and is not sensitive to load-switching events.

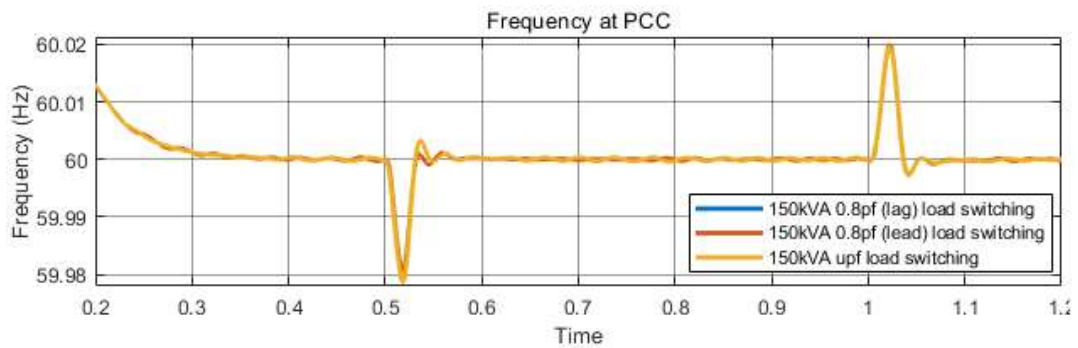

Fig. 5.8 PCC frequency for the system under load switching with proposed hybrid IDS.

5.4.3 Operation under capacitor and motor switching

In the grid-connected mode of operation, the proposed hybrid method is tested under motor and capacitor switching events. The objective of the test, in this case, is to verify that the method is not sensitive to the events, such as motor and capacitor switching, and is not erroneously operating. A 160 HP, 460 V, 60 Hz Induction Motor (I.M.) load is turned ON and OFF at 0.5s and 1s, respectively, to evaluate the performance under motor switching. Similarly, a 150 kVAr capacitor bank is turned ON at 0.5s and turned OFF at 1s to test the performance under capacitor switching conditions. Fig. 5.9 depicts the simulation results wherein the system frequency lies within the relay threshold limits for both I.M. and capacitor switching events.

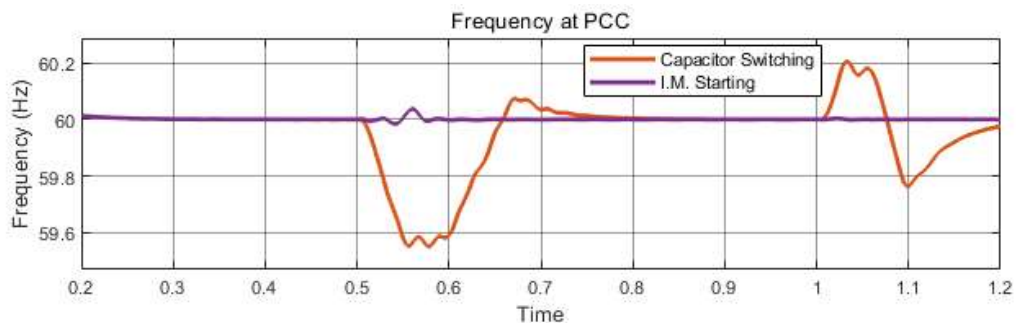

Fig. 5.9 PCC frequency for the system under capacitor switching and I.M. starting with proposed hybrid IDS.

5.4.4 Operation under different fault scenarios

A fault is an abnormal state in system operation in which voltage and frequency deviate from their nominal values. Small fault impedances result in significant fault currents, causing voltage and frequency to depart from the bounds of the (Over-Voltage/Under-Voltage) OV/UV and OF/UF relays. When the fault impedance is high, the voltage and frequency do not deviate from the voltage and frequency relay settings (NDZ). In this situation, anti-islanding detection may be confused with the islanding state and cause a false trip. Four examples of different types of faults with a fault impedance of $1\text{m}\Omega$ were simulated, considering fault occurrence at 0.5s and fault being cleared at 1s, to test the performance of the method during fault events. The simulation results are depicted in Fig. 5.10.

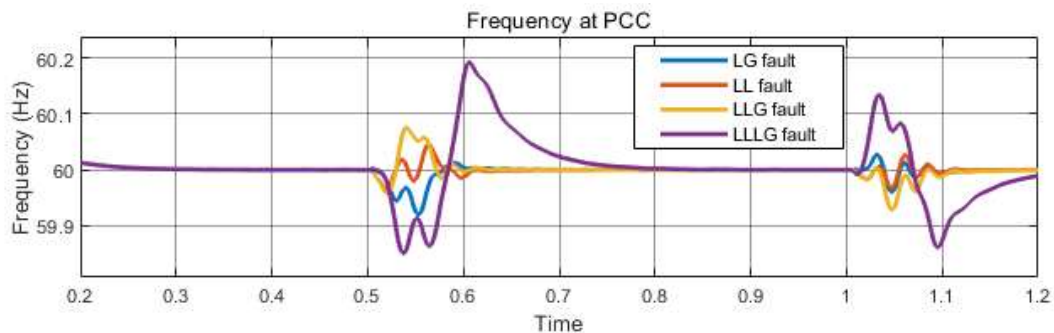

Fig. 5.10 PCC frequency for the system under different types of faults with proposed hybrid IDS.

Further, four more cases of the most severe fault (LLLG) with different fault impedances have been simulated to show the scheme's efficacy under High Impedance Faults (HIF) as well. The simulated results are presented in Fig. 5.11. It can be readily observed from Fig. 5.10 and Fig 5.11 that the proposed hybrid IDS performs satisfactorily under all types of fault events and does not confuse between fault and islanding events even under high impedance faults.

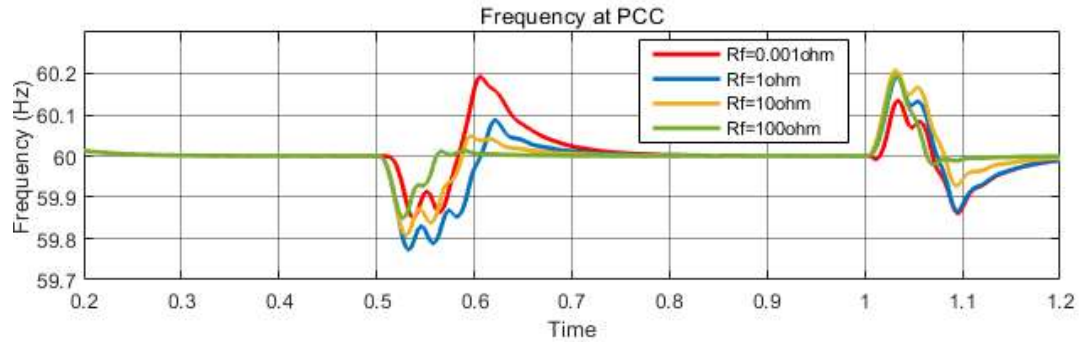

Fig. 5.11 PCC frequency for the system under LLLG fault with different fault impedance with proposed hybrid IDS.

5.4.5 Operation under different X/R ratios of the grid

While evaluating the efficacy of the proposed approach, another scenario that needs to be considered is the operation of the scheme in a weak grid situation. When the X/R ratio of the grid is significantly high, the power system is termed weak. Under this circumstance, the power system has a low short-circuit level and a little stability margin. In the case of a weak grid, frequency deviates more than in the case of a strong grid. The parameters of the conventional SFS islanding method, i.e., positive feedback gain and chopping fraction, continuously injects intentional disturbances in the grid. The frequency variations arising out of the continuous operation of the SFS technique may pose a stability problem for the reasons stated above. To put the proposed approach to the test, a constant impedance of 0.412Ω is used, and the X/R ratio is varied from 5 to 20. The results shown in Fig. 5.12 indicate that the hybrid IDS performs normally in the case of different X/R ratios and does not have any negative influence on system stability.

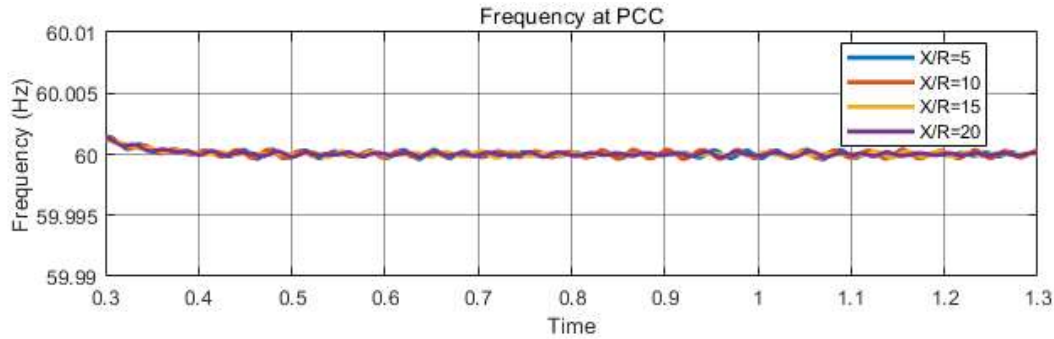

Fig. 5.12 PCC frequency for the system under different X/R ratios with proposed hybrid IDS.

5.4.6 Operation under different load quality factors

The load quality factor is one of the most essential load parameters taken into account to evaluate the proposed IDS. There are several standards and test settings, each considering a distinct load-quality factor in order to test the performance of the IDS. For example, in IEEE Standard 929, the use of $Q_f \leq 2.5$ is recommended; but, under IEEE 1547 and UL1741 test conditions, the use of $Q_f = 1$ and $Q_f \leq 1.8$, respectively, is recommended. In this work, the system under investigation is simulated over a wide range of Q_f ranging from 0.5 to 2.5 in order to demonstrate that the suggested hybrid scheme is efficient under all test criteria established by different standards. The load quality factor is varied by changing the load LC (parallel RLC branch) while keeping the impedance of the load constant.

As can be seen from Fig. 5.13, the islanding is incepted at 0.5s, and the frequency deviates from the under/over-frequency relay thresholds for all Q_f values while using the suggested hybrid IDS. In other words, given a large range of Q_f , evaluated by different standards, islanding can be detected by the proposed hybrid scheme within a short duration of time after the islanding event is incepted. A slight frequency deviation from the nominal value during the islanding event forces a rapid change in the inverter phase

angle through the proposed M-SFS method. Depending upon the direction of deviation (positive or negative), the inverter phase angle in-turn alters the inverter output current till the frequency crosses relays OF/UF threshold limits. In this case, for all the Q_f values, the frequency deviates in the positive direction at the instant of islanding inception, i.e., 0.5s, and hence, the proposed M-SFS method forces the frequency to cross OF threshold limit in the positive direction.

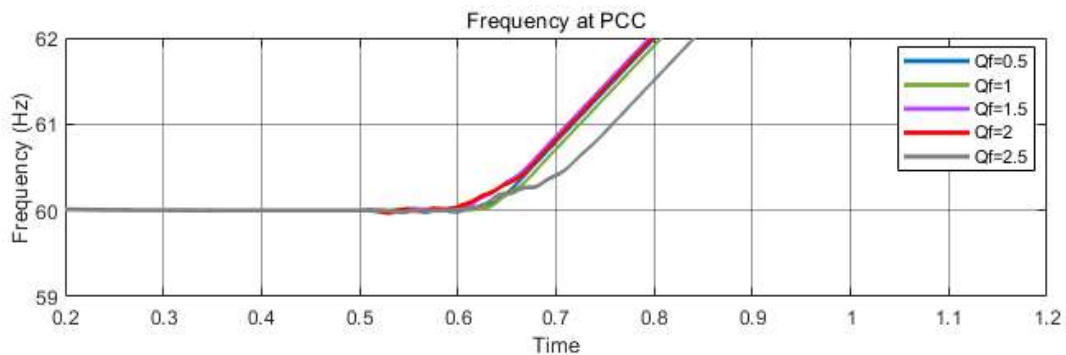

Fig. 5.13 PCC frequency for the system under different Q_f values with proposed hybrid IDS.

5.5 SUMMARY

In this work, a combination of the M-SFS method and FROCOF relay has been utilized for islanding detection. The proposed method presents the benefits of both active and passive methods, and it can effectively discriminate between various islanding and non-islanding conditions over a wide range of operating scenarios. The performance of the conventional SFS method heavily depends on its positive feedback gain, and hence, a modification in the method was proposed that significantly reduced the value of the positive feedback gain for the M-SFS method. The proposed method has been studied under different conditions of test requirements. The simulation studies concluded the following results on the efficiency of the proposed hybrid method:

- 1) The proposed hybrid IDS can accurately detect islanding even under a very small mismatch in active/reactive powers.
- 2) The proposed scheme decreases NDZ and improves the speed of response in comparison with conventional SFS.
- 3) The steady state power quality of the system is improved as the active method does not inject disturbances into the system continuously. Furthermore, the elimination of the chopping fraction also reduces the PQ disturbances, even for the periods when M-SFS gets activated.
- 4) The proposed method effectively discriminates between various islanding and non-islanding events such as load switching, I.M. and capacitor switching; and hence prevents any false tripping of the breaker.