CHAPTER 1

INTRODUCTION

1.1. Motivation

With the increase in world population, the demand for the fruits, vegetables, and other agricultural products continuously going on increasing but the availability of these products depends on the seasonal and climatic conditions, so it is needed the storage and transportation of these products without any deterioration to fulfill the world demand. Drying is one of the oldest and best methods for preserving and maintaining the quality of agricultural products. Drying conserved the product by removing the amount of moisture content from the products, while freezing conserves the product by maintaining its temperature below the freezing point of water (Goh et al., 2011). The drying of the product permits less weight for transportation and less space for long time storage without deterioration. Drying methods include convention solar, oven, dehydrator, and heat pump system. The drying methods must be designed in compliance with the recent environmental and energy policies (Alves et al., 1998). People reported that drying is one of the most energy-intensive unit operations that easily account for up to 15% of all industrial energy utilizations. And it is well known that the conventional methods of drying the fruits, vegetables, medicine, drugs, and timbers are time-consuming processes with huge wastage of energy (Colak and Hepbasli, 2009). In many industrial drying processes, a very huge amount of energy is wasted, so it is needed to develop new technology in the area of drying which is more efficient and with low pollution emissions. Also, due to globalization and market expansion, a newly developed product quality must conform to a wide consumer's preferences and expectations. It was reported in a study that drying consumes up to 70% of the total energy in manufacturing wood products,

50% of the total energy consumption in the manufacturing of finished textile fabrics, and over 60% of the total energy needed for farm corn production (Mujumdar, 1995). Therefore, energy management is an essential part of the drying process and efficient energy conservation contributes significantly to the overall operating cost. By applying a better method of drying to the products it may be possible to reduce the energy requirement, drying cost, and environmental pollution with better product quality and color.

Different conventional methods of drying are available for food products and people used different methods of drying for industrial and domestic applications. The sun drying method is the oldest and most natural available source without any cost but it is a too time-consuming process and the intensity of the sun is also not constant, and the sun drying is mostly suitable for the fruits having high sugar and acid content. Vegetables and meats are not suitable for sun-drying due to the low content of sugar and acid in vegetables and meat (high protein). In sun drying the temperature (low) and the humidity is uncontrolled which may damage the food products which are outside the door (Ahmed et al., 2013). The power consumption in hot gas drying is very high and it is not ecofriendly due to pollution generation also it is not suitable for the low-temperature drying products with the high cost of drying. The vacuum drying is proposed to alleviate some disadvantages of hot air drying. The main purpose of vacuum-drying is to allow the removal of moisture under vacuum and hence at a lower temperature condition and oxygen content. Vacuum-drying is, therefore, suitable for heat- and oxygen-sensitive materials. During vacuum drying, the rate of evaporation increases (at a fixed temperature) since the boiling point of water is reduced. In addition, the effective hydraulic conductivity of a material increases under vacuum, so the resistance to mass transfer at the product surface reduces. Vacuum-drying consequently requires less drying

time than conventional hot air drying and in most cases results in a higher quality dried product. The main disadvantage of the vacuum drying is that it is suitable for the low temperature drying only and the power consumption is very high with the difficulty of maintaining the vacuum in the drying cabin (Amellal and Benamara, 2008). By combining the factors of heat, low humidity, and air flow, an oven can be used as a dehydrator. An oven is ideal for occasional drying of fruit leathers; banana chips or for preserving excess produce like celery or mushrooms. Because the oven is needed for everyday cooking, it may not be satisfactory for preserving agricultural food products. Oven drying is slower than dehydrators because it does not have a built-in fan for air movement. (However, some convection ovens do have a fan). It takes about two times longer to dry food in an oven than it does in a dehydrator. Thus, the oven is not as efficient as a dehydrator and uses more energy. Microwave drying is only suitable for the low quantity drying of the herbs and the vegetable leaves. The drying cost of microwave drying is high because energy consumption is high for the microwave heater and it is not successful for most other agricultural food products. Freeze-drying is typically used to preserve a perishable material or make the material more convenient for transport. Freeze-drying works by freezing the material and then reducing the surrounding pressure to allow the frozen water in the material to sublimate directly from the solid phase to the gas phase. It is the costly method of drying compared to the other method (Ahmed et al., 2013). The above discussed conventional methods of drying have some advantages and as well as disadvantages. So it is needed to develop a new method of drying that can minimize the disadvantages of the conventional method of drying.

Recently people are taking interest in utilizing the heat pump dryer (HPD) for drying fruits, vegetables, and biological materials. The heat pump is a very energy-efficient heating and cooling system, so it can be also used as a convective dryer

efficiently by removing the moisture from the products with a low cost of drying and high moisture removal rate. The main advantages of using heat pump dryer technology are the energy-saving potential with high energy efficiency and the ability to control drying temperature and air humidity at the drying chamber inlet which provides a wide range of drying conditions for the different materials dried at different temperatures (Claussen et al., 2007). So with the heat pump dryer, the temperature and the moisture-sensitive materials can be dried without deterioration of the product quality and color. Utilization of the heat pump as convective hot air dryers has been recognized as a new area of the application of the heat pump instead of heating and cooling only because the energy efficiencies of conventional dryers are generally very low, and the maximum value of the energy efficiency was for the simple conventional dryer as a value of 35% (Schmidt et al., 1998). Also, it was found that the heat pump dryer consumes 60–80% less energy as compared the conventional dryers operating in the same temperature range. Thus the heat pump dryer may be a feasible option for users who are not satisfied with the comparatively high energy consumption of conventional hot air dryers.

But the simple heat pump dryer having also some limitations the using the costly electric energy (responsible for greenhouse gases and flying ash production in thermal plants) and longer drying time due to low-temperature drying. The leakage of the conventional refrigerants directly into the atmosphere from the heat pump system also contributes to the ozone layer depletion and the global warming effect, so it is needed to study the performance of new refrigerants with low global warming potential (GWP) and ozone layer depletion potential (ODP) for the heat pump drying application. During the last decades, environmental issues have evolved from pollution and depletion of natural resources, such as climate change, and fossil fuel consumption contributes to these damages. From the viewpoint of environmental problems, developing sustainable and

renewable energy sources and improving the efficiency of systems using thermal energy has become important because renewable energy sources produce negligible pollution, and the cost of energy is also low. So it is needed to design and develop a new system that can remove the limitations of the simple heat pump dryer for the agricultural products drying and utilizes the renewable and other energy sources with the heat pump system. The hybrid source heat pump dryer utilizes unconventional energy sources such as solar energy, ground source energy, and waste heat recovery source with a heat pump system which decreases the electric energy consumption with the improved thermal performance and drying time as compared to the simple heat pump dryer. The drying temperature range for the hybrid source heat pump dryer may be greater than the simple heat pump dryer which improves the drying rate and energy efficiency. It is supposed that the heat pump dryer and the hybrid source heat pump dryer have better overall drying and thermal performance characteristics with a low cost of drying over the conventional drying methods. Recently hybrid source heat pump dryers are getting importance due to their enhanced thermal performance and lower environmental issues and drying cost, which has motivated to apply the solar energy source with heat pumps for food products drying. The drying performance of hybrid source HPD should be high due to higher drying temperature but the product temperature may be increased continuously by continuous drying, and the drying material (both product surface and quality) can be deteriorated due to continuous high-temperature heat input and hence the drying should be carried out at optimum temperature. To avoid the deterioration of the food products, intermittent drying may be applied because in intermittent, the energy supply is in different steps and the drying temperature may be maintained at an optimum level.

1.2. Heat pump dryer

The first heat pump dryer patent applications were started in 1973 and the first study on the heat pump dryer available in the open literature on the timber drying with the heat pump dryer evaluated the energy consumption and the performance parameters of the timber drying (Geeraert, 1976). The heat pump drying system is the combination of mainly two subsystems; a heat pump system and a drying chamber system. Heat pumps are a cooling and heating system (refrigerators) that delivers the heat energy (high temperature) in the condenser gained by cooling in an evaporator from a low-temperature energy medium (drying air) with the addition of further external energy (compressor energy input) to a higher temperature level. The term heat pump refers to the fact that it can be used as simultaneously in both the heating and cooling system (Mujumdar, 2006). In the heat pump, the cooling and heating system is used both for the moisture removal and the heating of the drying medium. Heat pumps are the device that can transfer heat from the natural heat sources available in the surrounding atmosphere, such as the air, ground, water, industrial or domestic waste, chemical reaction, or dryer exhaust air. The second most important part of the heat pump dryer is the drying chamber. The drying chamber may be of different types such as a tray, fluidized bed, rotary, or band conveyor type. Depending on the different types of energy utilization, the heat pump dryer can be classified as a simple heat pump dryer and the hybrid source heat pump dryer. Fig. 1.1 shows the classification of the heat pump dryer.

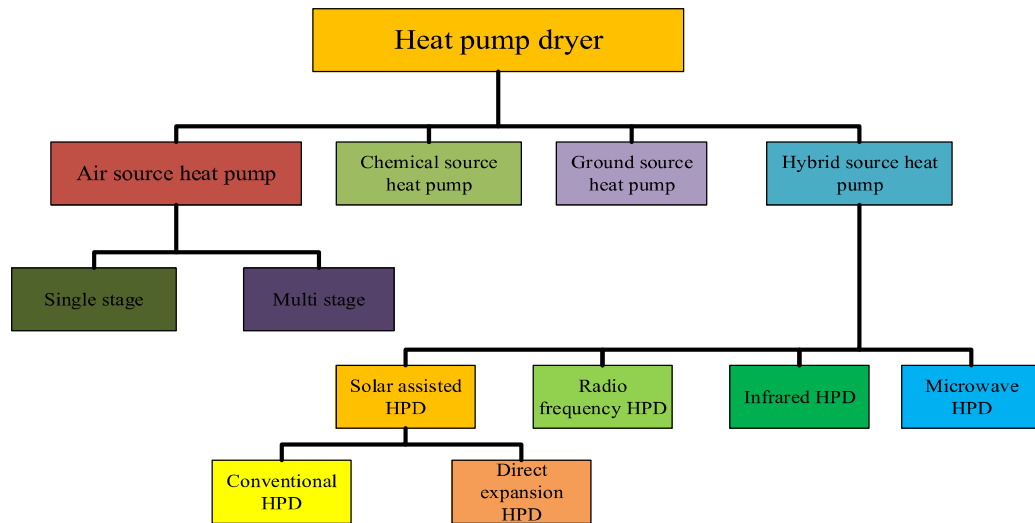

Fig. 1.1: Classification of heat pump dryer

1.2.1. Air source heat pump dryer

The main components of the air source heat pump drying systems are an evaporator, a condenser, a compressor, and an expansion device. As shown in Fig. 1.2, in a heat pump drying system, the working fluid (refrigerant) at low pressure and temperature is vaporized in the evaporator by heat removed from the dryer exhaust air (recirculated to evaporator). The compressor increases the pressure and the temperature of the refrigerant of the heat pump by consuming the high-grade energy (electric or mechanical) and discharges the refrigerant in a superheated state of vapor at high pressure to the condenser. The heat pump delivers the removed heat from the working fluid (refrigerant) to the working drying medium (drying air) in the condenser. In the drying system, the heated air coming out from the condenser is directly allowed to pass (recirculation) through the drying chamber where the drying medium removes the moisture from the product to be dried by exchanging energy. The refrigerant in the heat pump from the condenser is then throttled (isenthalpic expansion) to the low pressure by using an expansion device and then this low pressure and temperature refrigerant enter into the evaporator to complete the refrigeration cycle in the heat pump dryer. In the drying chamber, the hot and the dry air removes the moisture from the product and then passes

through the evaporator where the moisture of the air removes by the condensation process as the air temperature goes below the dew point temperature. In the simple heat pump dryer (air source), the input energy is only to the compressor (electric or mechanical) which is used to circulate the refrigerant in the cycle through the different components of the heat pump cycle.

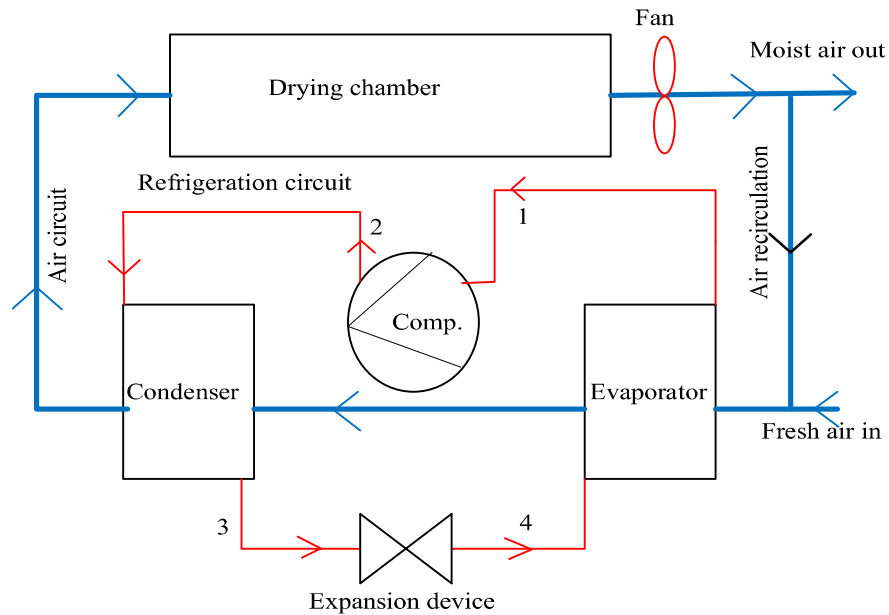

Fig. 1.2: Schematic diagram of heat pump dryer

1.2.2. Ground source heat pump dryer

In the ground source hybrid heat pump dryers, a renewable source of geothermal energy is utilized with the heat pump cycle for the drying of the products. In the ground source heat pump dryer, the refrigerant in the evaporator is converted into vapor by gaining the heat directly from the ground source instead of the recirculating drying air. Figure 1.3 represents the schematic of the ground source-assisted heat pump dryer. The ground is a thermally more stable heat exchange medium than air, essentially unlimited and always available. The ground source heat pump dryer exchange heat with the ground, and maintain a high level of performance even in colder climates. The main advantage of the ground source heat pump dryer is that it utilizes the renewable form of ground

source energy which reduces the electricity consumption of the compressor with improves the performance of the system.

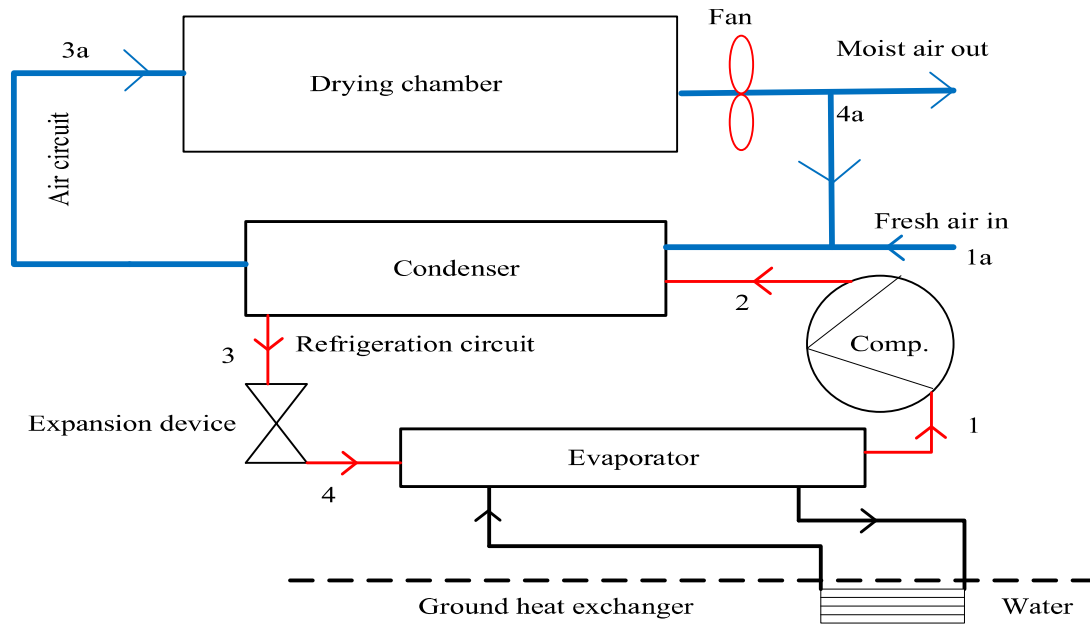

Fig. 1.3: Schematic diagram of ground source assisted heat pump dryer

1.2.3. Chemical source heat pump dryer

A chemical heat pump drying system that uses the chemical source of energy for the drying purpose may be an effective utilization of thermal energy in drying with energy-saving and less environmental impact. A heat pump dryer can store thermal energy in the form of chemical energy by an endothermic reaction and release it at various temperature levels for heat demands by exothermic reactions. Figure 1.4 represents the schematic of the chemical source heat pump dryer. A chemical heat pump dryer has potential for the heat recovery and dehumidification in the drying process by heat storage and high/low-temperature heat release. The chemical heat pump dryer can store thermal energy from the various source such as the waste heat from dryer exhaust, solar energy, geothermal energy, etc. in the form of chemical energy via an endothermic reaction in a suitably designed reactor and release the energy at various temperature levels during the heat-demand period by exothermic reactions.

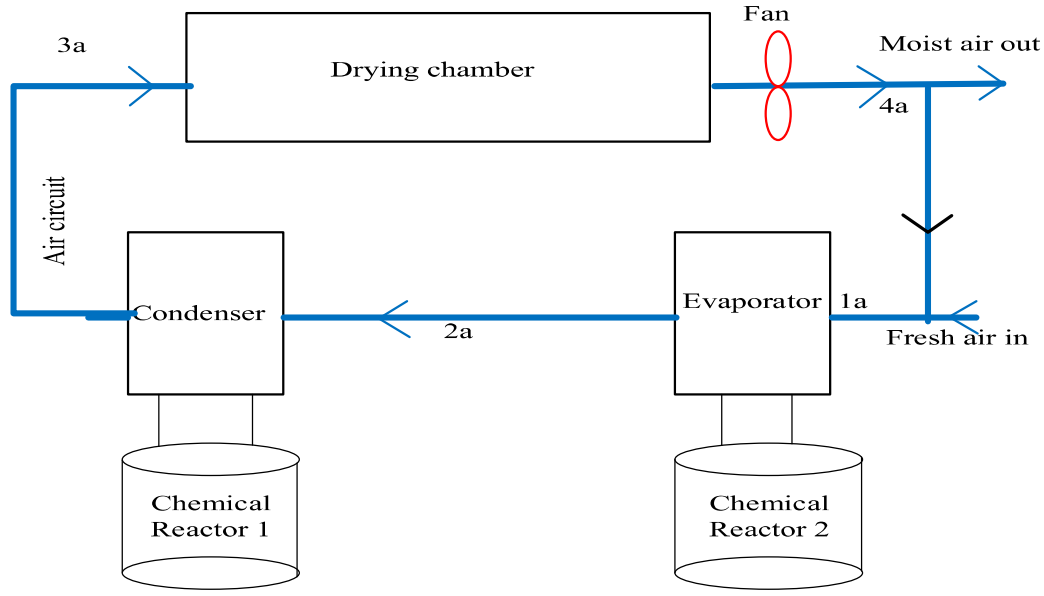

Fig. 1.4: Schematic diagram of chemical source heat pump dryer

1.3. Hybrid source heat pump dryer

Integration of the air source heat pump dryer with the other form of energy sources such as solar energy, ground source energy, etc. is called a hybrid source heat pump dryer. In the hybrid source heat pump dryer, the drying temperature can be higher than the simple air source. The main advantage of the hybrid source heat pump dryer is that it can utilize the renewable source of energy (Ex. Solar, ground source) with a heat pump for the drying purpose with better and improved performance than the air source heat pump dryer. A hybrid source of the heat pump dryer can provide effective control of the air humidity and the temperature in an energy-efficient manner. The hybrid source heat pump dryer can be classified based on the external source energy input. Fig. 1.1 shows the classification of the heat pump dryer.

1.3.1. Solar assisted heat pump dryer

A solar-assisted heat pump drying system is the combination of the vapor compression heat pump cycle and a solar collector and this combined system may be able to provide better thermal and drying performance than the simple heat pump dryer. Solar-assisted heat pump drying systems can be classified as conventional solar-assisted heat

pump drying systems and direct-expansion solar-assisted heat pump drying systems. In a direct expansion system, the solar collector system consists of a solar collector, a heat exchanger as the condenser, an expansion device, and a compressor. The solar collector is used as the evaporator of the heat pump system dryer and the refrigerant is directly vaporized in the solar collector–evaporator due to the solar energy input. But in a conventional solar-assisted heat pump dryer a separate solar collector and the heat exchanger are used with the heat pump cycle and the drying air is pre or post-heated in the solar heat exchanger while passing through the condenser. Figure 1.5 shows the schematic diagram of the conventional solar-assisted heat pump dryer. The main advantage of the solar-assisted heat pump dryer is that it can utilize the renewable source of solar energy (free of cost) with higher drying temperature and reduces the primary energy (electric) requirement which finally reduces the chances of pollution. Heat pumps driven by electricity produced from hydropower or renewable energy, reduce emissions more significantly than if the electricity is generated by coal, oil, or gas-fired power plants (Dincer, 2003).

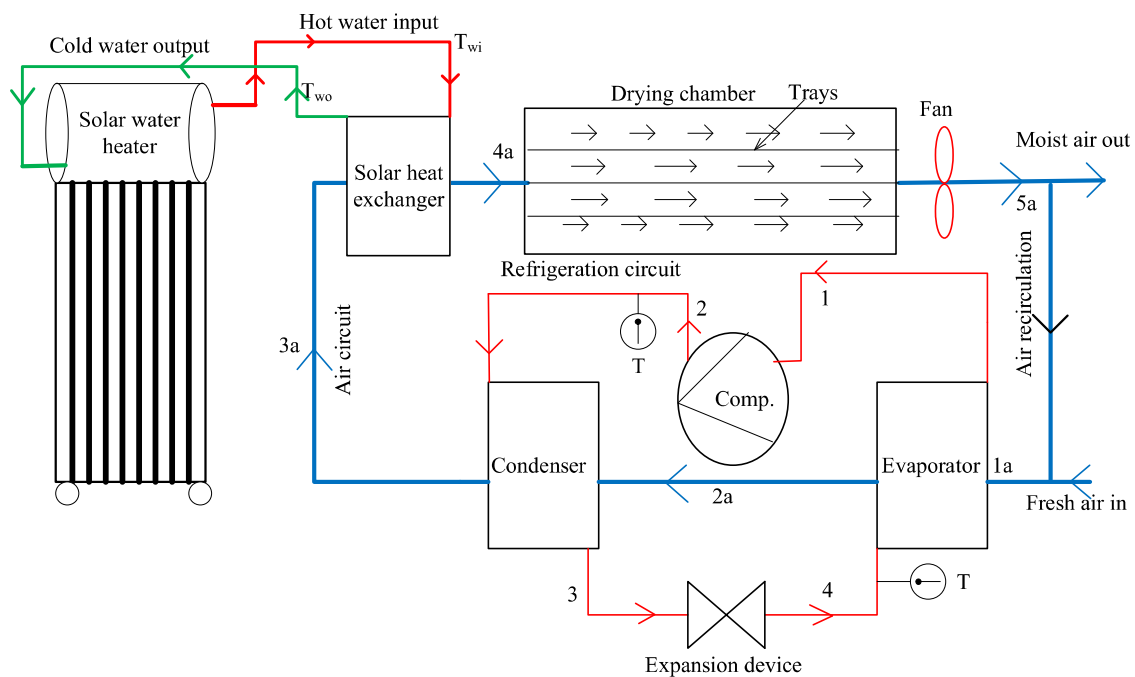

Fig. 1.5: Schematic diagram of Solar assisted heat pump dryer

1.3.2. Microwave-assisted heat pump dryer

Microwave-assisted heat pump dryer utilizes the energy of the microwave radiation with the heat pump cycle to remove the moisture from the product at a faster rate. This type of hybrid source heat pump dryer uses microwave radiation which penetrated the drying material which creates a vapor pressure gradient and removes the moisture from the product at a faster rate. However, the application of microwave drying in industrial processes has been relatively slow since this technique requires a high capital investment and suffers a low energy efficiency of drying when compared with conventional drying technologies. To make the economics of microwave drying more attractive for industrial applications, it is necessary to incorporate additional energy-conserving features, such as heat pumps (Shane et al., 1993). Figure 1.6 represents the microwave-assisted heat pump dryer.

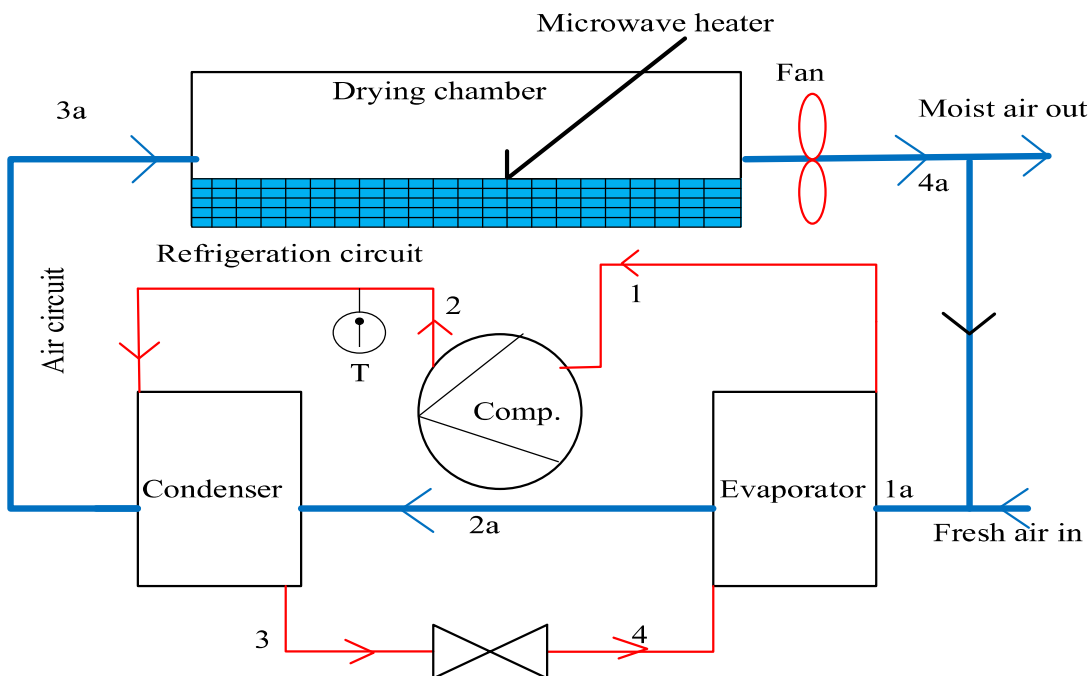

Fig. 1.6: Schematic diagram of microwave-assisted heat pump dryer

1.3.3. Infrared assisted heat pump dryer

Infrared-assisted heat pump dryer uses the infrared energy source with the heat pump cycle to remove the moisture from the drying product. In this type of hybrid source

heat pump dryer, the infrared radiation (heater or lamp) is installed inside the drying chamber, and the infrared radiation is penetrated inside the material and develops a vapor pressure gradient. Due to this developed vapor pressure gradient, the moisture extracted at the surface of the material and carried away by the hot drying air coming from the condenser of the heat pump. The infrared-assisted heat pump dryer is used where a faster rate of drying is required. This method is not too economical and eco-friendly due to the high energy consumption by the infrared radiation source. Figure 1.7 shows the schematic diagram of the infrared-assisted heat pump dryer.

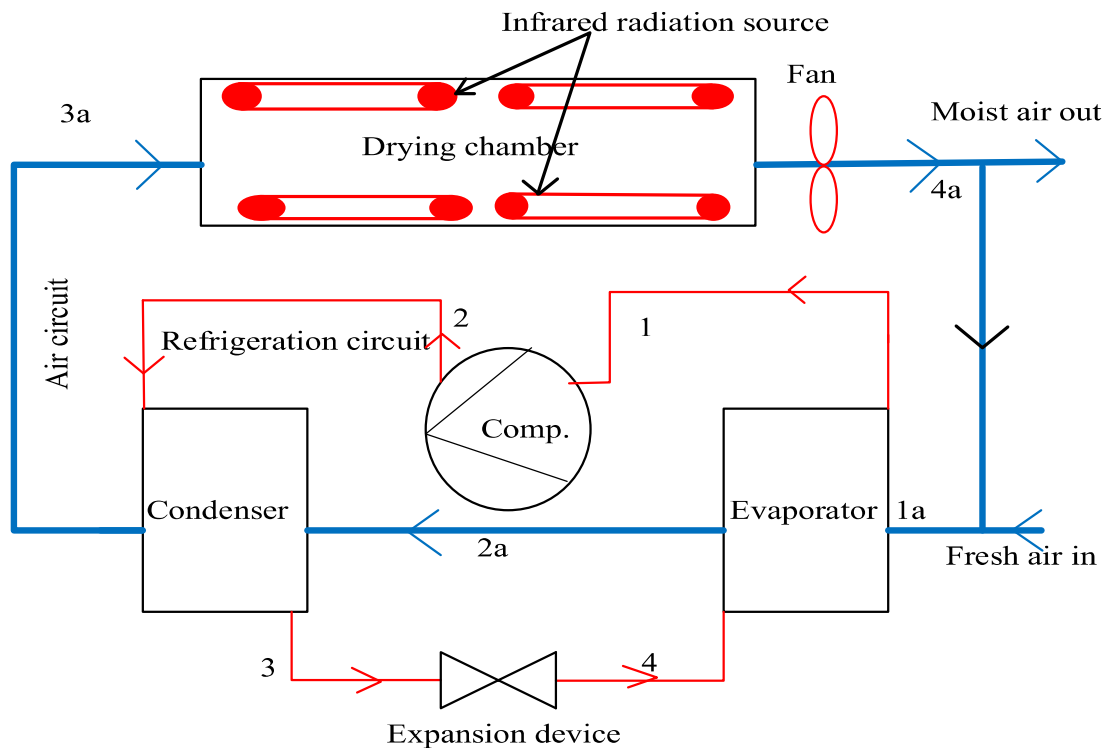

Fig. 1.7: Schematic diagram of infrared assisted heat pump dryer

1.3.4. Radio frequency assisted heat pump dryer

Radio frequency assisted heat pump dryer is the combination of the heat pump cycle and the radio frequency generating system capable of imparting radio frequency energy to the drying material at various stages of the drying process. This radio frequency energy helps to break the dipole bonds between the water molecules inside the products and removes the moisture at a faster rate as compared to the simple heat pump drying

system. Figure 1.8 represents the schematic diagram of the radio frequency assisted heat pump dryer.

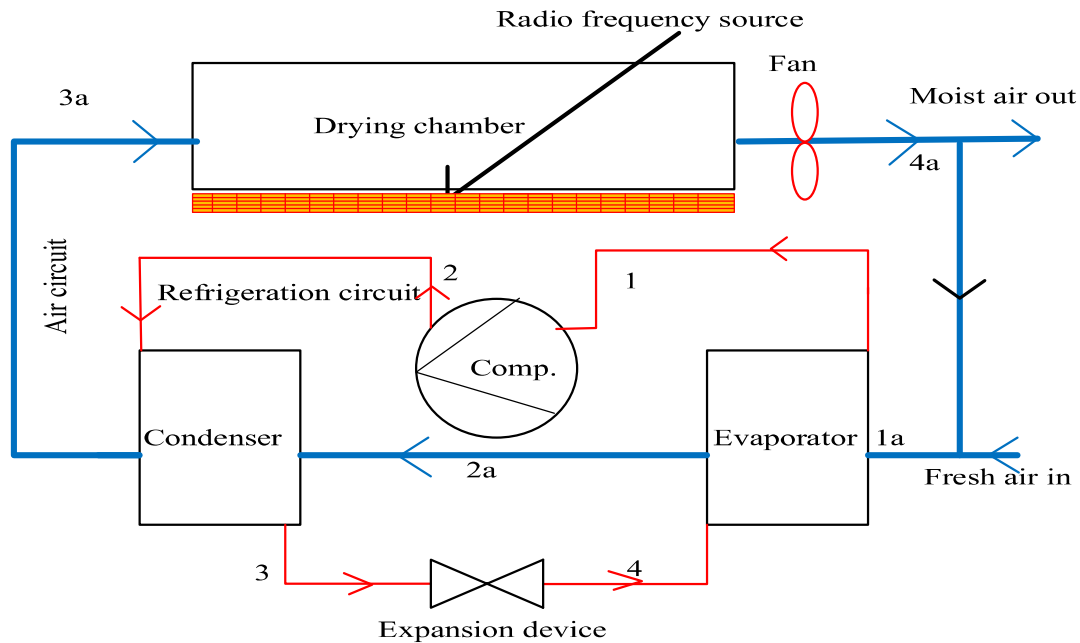

Fig. 1.8: Schematic diagram of radio frequency assisted heat pump dryer

1.4. Contribution of the study

The main contribution of this study is to design, develop, and performance analysis of the simple heat pump dryer and the hybrid source heat pump dryer for the drying of the different types of drying material. In this study, the experiment is performed for the drying of banana chips and potato with a simple air source heat pump dryer in an open and closed-loop system. The energetic and the exergetic performance comparison of the different low global warming potential (GWP) refrigerants have been carried out numerically for the heat pump drying application. The economic, exergoeconomic and the performance investigation is carried out for the hybrid source heat pump dryer which is the combination of the solar energy, infrared energy source, and the heat pump system for the radish chips drying. This study also studied the hybrid source heat pump dryer assisted with waste heat recovery from the IC engine exhaust (diesel engine). A solar-assisted heat pump dryer is developed and experimented with using the solar water heater

as a solar energy source and the economic, exergoeconomic, and thermal performance is investigated. The novelty of the present study is that the combination of the three types of energy solar, infrared, and the heat pump is studied for the food chips drying. The thermal performance, economic, and the exergoeconomic study of the solar-assisted heat pump dryer is carried out in this study for the first time using the solar water heater as an energy source for the drying system. For the very first time, the waste heat from the exhaust of a diesel engine is utilized as the energy source with a heat pump dryer. The intermittent drying with a solar-assisted heat pump dryer is carried out for the first time in this research analysis using energy, exergy, and economic methods. A heat pump dryer with air conditioning (combine HPD + air conditioning) is studied to evaluate the performance of the combined system with a single energy input source. The variation of the different parameters such as moisture extraction rate (MER), specific moisture extraction rate (SMER), drying rate, drying efficiency, energy efficiency, second law efficiency, and the exergy destruction is studied according to with drying time.

1.5. Thesis structure

This study is distributed in nine chapters. In the **first chapter**, the basic background, including the simple heat pump dryer and hybrid source heat pump dryer and thesis contribution are provided. In the **second chapter**, a literature survey on the theoretical and experimental study on simple heat pump dryers and the theoretical and experimental study on hybrid source heat pump dryers including the drying temperature and the type of refrigerant, and the energy sources used. In the **third chapter**, a numerical study of the heat pump dryer for the design and the performance of a simple heat pump dryer for the different types of future refrigerants is studied and the performance of the drying system is evaluated. **The fourth chapter** included the design, development, and experimental analysis of the simple heat pump dryer for the drying potato and the banana

chips in an open and closed system. In the **fifth chapter**, design development and the performance analysis of the solar-infrared assisted heat pump dryer are included in the closed system for the drying of banana chips. In this chapter, the energy, exergy, economic, and the exergoeconomic analysis are performed. **The sixth chapter** contains the details about the performance analysis of the heat pump dryer with waste heat recovery from the IC engine exhaust using the energy-exergy and economic-exergoeconomic methodology. In the **seventh chapter**, the experimental study of the intermittent drying of the solar-assisted heat pump dryer is included with a closed system for the drying of the agricultural products. In this chapter, the performance, economic and exergoeconomic analysis of the solar-assisted heat pump intermittent drying of food chips is presented. The analysis of the heat pump dryer integrated with the air conditioning in a hot atmosphere is included in the **eighth chapter**. In this chapter, the performance of the heat pump dryer with air conditioning is carried out in a single heating and cooling system. Finally concluding remarks from the all numerical and experimental study of the heat pump dryer and the hybrid source heat pump dryer and the future scope of the present study are presented in the **ninth chapter**.